

Model Railway Electronics for Beginners (9th year)

© Howard Watkins
Missenden Abbey
1-2 October 2016
Updated 1 October 2016

Course Synopsis

- Theory & Practice of Soldering.
- Tools & Supplies.
- Meters
- Joining wires Practical
- Component recognition
- Basic Maths.
- Building a kit
- Fault Finding
- Baseboard wiring
- Wire sizes
- Wiring points
- Introduction to DCC
- Choosing a MERG kit
- Driving point motors
- LEDs
- A case study on wiring a baseboard

Copyright ©

- Some of the material in this presentation has come from “The Electronics Club” & is reproduced with permission <http://electronicsclub.info/>
- The Turnout Wiring Guide is reproduced by permission of Andy Reichert <http://www.proto87.com>
- The images of LED FlickerFree and Axle springs are reproduced by permission of Richard Johnson <http://www.dccconcepts.com>
- The majority of images are reproduced by permission of Rapid Electronics. <http://www.rapidonline.com>

Abbreviations

- Where appropriate, Rapid part numbers are shown with an indication of price e.g. (85-1140, ~£26).

<http://www.rapidonline.com>

- Examples of circuits used in “Crocodile Clips” give the file name e.g. “MISD5”



Theory & Practice of Soldering

What is Soldering?

- It bonds the parts metallurgically.
- It combines with the surface atoms of the two metals to be joined & forms a new alloy.
- It forms an excellent electrical connection as well as a strong mechanical joint between the metal parts.

How to Solder

Soldering needs to be

- 1) hot enough
- 2) clean enough
- 3) for long enough
- 4) quick enough
- 5) still enough

But not this hot!



How to Solder – Hot Enough

- Adequate temperature ensures we can melt the solder.
- Best is 50W temperature Controlled Iron
- However I often use an Antex 25W iron (85-1140, ~£26) as this is light and very portable.
- Boiled flux (that fizzing) and charred flux (that black crud) indicates overheating.

How to Solder – Clean Enough

- components leads should not need cleaning (unless VERY old).
 - PCBs use coated tinned areas to reduce oxidation, or are gold plated. They should not need cleaning.
 - For wire, strip the insulation to get untarnished wire.
 - Flux helps remove any oxidation layer
- BUT**
- For electronic kits, a separate flux is **NOT** needed if resin cored solder is used.

How to Solder – Long Enough

- Place the wetted iron on the PCB and touch the component lead.
- Count to 3 (or longer) then add solder ;
"iron-2-3, solder-2-3, cool-2-3" .
- Exact time depends on the iron, size of component, anything else connected on the PCB etc.
- cutting the excess leads before soldering reduces the time.

How to Solder – Quick Enough

- Ideally we want to get “in and out” as quickly as possible, hence the ability to deliver HEAT is the most important, so we
 - don't damage Electronic components
 - don't melt plastic sleepers when soldering droppers
- The secret is to use a very hot iron so that tinning takes place before heat spreads to any plastic.

How to Solder – Still Enough

- If the component/wire moves while the solder is still fluid, you may get a poor joint with little or no electrical contact.
- Known as a “dry joint” (i.e. not wetted).
- May show itself as non-shiny joint.

Various Types of Solder

1. Solder for White Metal Kits
2. Lead Free Solder (not recommended)
3. Solder for etched kits (no internal flux)
4. 60/40 tin/lead with internal flux (recommended)
5. 60/38/2 tin/lead/silver better still

N.B. use separate Bits for 1, 2 & (3/4)

Also consider

- Size of solder
- Melting point
- Surface tension of solder

The Perils of Lead Free

typically lead free solder needs

- more aggressive flux
- higher temperatures
- longer iron dwell times.

It is almost impossible to recognise a good joint from a bad joint visually, because even a good lead free joint is typically grey, not the nice shiny silver of a well made tin / lead joint.

Size of Solder

- Size, I use
 - 18 SWG for larger components (~1mm)
 - 22 SWG for Kits, wires, N Gauge track (~0.7mm)
 - 28 SWG for Surface Mount, Decoder fitting etc. (~0.45mm)
- Example: 100g reel of 22 SWG solder (85-0592, ~£5)
 - Contains Rosin flux (not acidic, so non corrosive)
 - Melting Point 188°
 - Set temperature to about 300 ° to 350 ° C

(Handout length of 22 SWG 60/40 Solder)

Flux

Flux is a paste or liquid used to-

- Help wet the surfaces to be soldered
- Help remove any oxidation layer.

For electronic kits with Printed Circuit Boards (PCBs), a separate flux is NOT needed if resin cored solder is used. Flux might be needed with stripboard (Veroboard).

- Never use acid flux for electrical connections - it will eat into the copper wire over time, and corrodes the soldering iron tip.

Solder Fluxes, Gels & Paste

1. PowerFlow flux (very aggressive), must be washed off immediately with Meths
2. Telux can be washed off with warm water.
3. “No clean Flux” e.g. SM rework jelly (85-6276, ~£18)





Tools & Supplies

Soldering Iron Stations

- Antex 50W (85-4752), with spare bits 0.5mm (85-0508) and even finer.
- Weller TCP series 24V, 50W & power supply (85-4852 & 85-4905), with bits down to 0.4mm (85-4656).
- Both are more expensive than fixed temperature ones (~£138-£170), but many users prefer them.
- Good first buy, more likely to get good results than with fixed temperature iron.

Mains Soldering Iron

- I have an Antex 50W temperature controlled Iron. Comes with a 2.3mm bit but I hardly ever use it. For Electronic Kits replace with 1mm bit (85-0510).
- Solder station may already be fitted with a silicone cable (available separately 85-0590).
- Discount irons may not have spares.
- Chisel tips are good, better still, get a “well” type bit (but Antex don’t supply them).

Mains Soldering Iron

- I now use a Hako FX888D-17 (~£120) available in the UK from

<http://www.dancap.co.uk/>

- I use T18-CF1 and T18-CF15 Tips (Chisel tips with a well)



Soldering Iron bits

- **NEVER** file the bit – it will ruin the plating, and copper will dissolve in the solder.
- Tin the tip on first heating it up (maybe several times).
- Use a damp sponge. A wet sponge causes thermal shock & can limit tip life.
- maybe brass wool cleaner (85-0554)
- Suggest tin of bit cleaner (85-0630)



Soldering Iron Stand

- Stand with sponge (get a spare sponge!)
- Antex ST4 (85-0585) or ST6A (85-4722), depends on size of soldering iron.



Other Tools

- Pliers, side cutters, spanners etc.
- Work Holder.
- Good Light .
- Magnifying glass...
- Kapton Tape ...
- Wire strippers ...
- Desoldering tools ...
- Multimeter & Test Leads ...
- MERG Bending Jig (794)



Magnifying Glass/Workholder

- “Helping Hands” (85-5930).
- More expensive ones have lights.
- Magnifying Lights (86-3330)
- Hold PCB with Bluetack/Wooden clothes pegs etc.



Kapton Tape (Carrs Hot Tape)

- Withstands high temperatures (400 C), good for holding small pieces, and for insulation during DCC decoder fitting.



- Also useful, spring clamps (86-8617) & piece of hardboard.



Wire Strippers

Automatic

0.2 mm to 6 mm
(86-0320) ~£16



Thin wire

(86-0367) ~£5.50



Cable sheath

4 mm to 16 mm
(86-0385) ~£18.50



Wire strippers

- To strip the insulation from the middle of a wire/cable, use (yet another) wire stripping tool (89-0884). Useful for DCC Bus Wires.



Fine Wire Strippers

- From DCCConcepts (Australia) available from Gaugemaster. Good (0.1mm to 3mm) but expensive ~£21.



Precision Wire Strippers

- Jonard 550 (from Mouser 801-ST-550).
Excellent (0.3 mm to 1 mm) but expensive
~£30.



Removing the insulation from fine wires

Instead of fine wire strippers-

- Burn off the insulation with a soldering iron.
- Does not damage any wires, but it is essential to wipe the iron clean of PVC afterwards.

DeSoldering Tools

De-solder pump
(85-0601)



Desoldering Iron
(85-0901), use
Maplin stand BP57M



Braided Wick
Various sizes
(85-0616), use with
liquid flux.



Desoldering Tip

- After removing a component, the hole in the PCB may still be filled with solder (plated through hole).
- This is hard to remove because the flux has disappeared due to the heat during the soldering/desoldering phase.
- Adding **MORE** solder helps because it is also adding flux.

Meters

Digital or Analog

- Digital tend to be more precise.
- Negative values are shown as such on Digital, may not show at all on Analog.
- Analog tend to respond quicker, so you may see a flicker on Analog but nothing on Digital especially if poor contact is made due to dirt, solder flux etc.
- Continuity test (beep) probably the most useful – yet not all meters have it.

Analog Multimeter e.g. 51-5173

- Resistance Scale
- Voltage scale (DC & AC)
- Current scale (DC & AC?)
- Continuity Beep (Buzz)
- Battery Test (9V & 1.5V)
- User Documentation (in German!)
- Cost ~£10

Neat & small, ideal for general model railway use.



Digital Multimeter e.g. (86-3181)

- Resistance Scale
- Voltage scale (DC & AC)
- Current scale (DC & AC)
- Continuity Beep
- Battery Test (9V & 1.5V)?
- Temperature probe
- Capacitance Test
- Transistor Test
- User Documentation?
- Cost ~£16



MERG Bending Jig (794)

Jig is hard plastic,
so does not
itself bend.

It is for bending
resistors etc. to
a 0.1" pitch
(Veroboard,
standard PCB
spacing)

Costs ~ £1.20

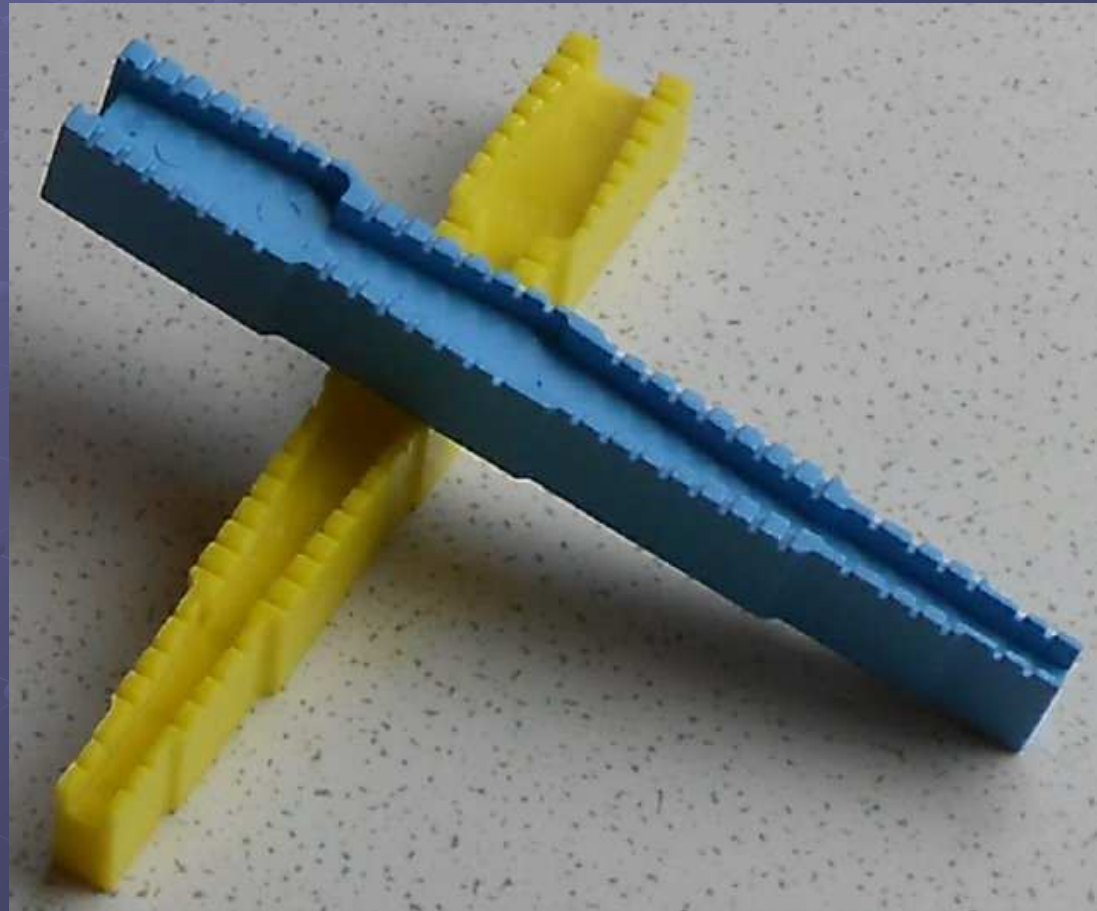

Heatshrink

- What is it?

- An insulating sleeve that shrinks when heated (better variety shrinks by a factor of 3)

- Why use it?

- It avoids bare wires and potential shorts
- It can be used to tidy a bundle of wires
- Can join thick wire to thin



Heatshrink

- 1.2m of **3:1** in various sizes
 - 1.5mm (03-1100)
 - 3mm (03-1105)
 - 6mm (03-1110)
- Shrink by using either
 - side of iron (do not touch it)
 - small Butane hot air gun.
(85-0802) ~£20.
Takes standard lighter.



Joining wires to other wires

Need for

- Strong mechanical joint
- Good electrical continuity
- Absence of bare wires (danger of shorting)

Also consider colour of wires to aid documentation

How to Solder Wires

1. Strip the insulation – ensures clean wire.
2. Add small length of heatshrink
3. Twist each wire & tin (i.e. solder the bare wire)
4. Twist finer wires/hold thicker wires together.
5. Apply solder iron then solder, remove iron, **keep the joint still for a few seconds**
6. Bend joint back along wires.
7. Move heatshrink over joint & heat it

if you forgot stage 2, undo & start again!.

How to Solder Electronic Kits

This is the effect to aim for -

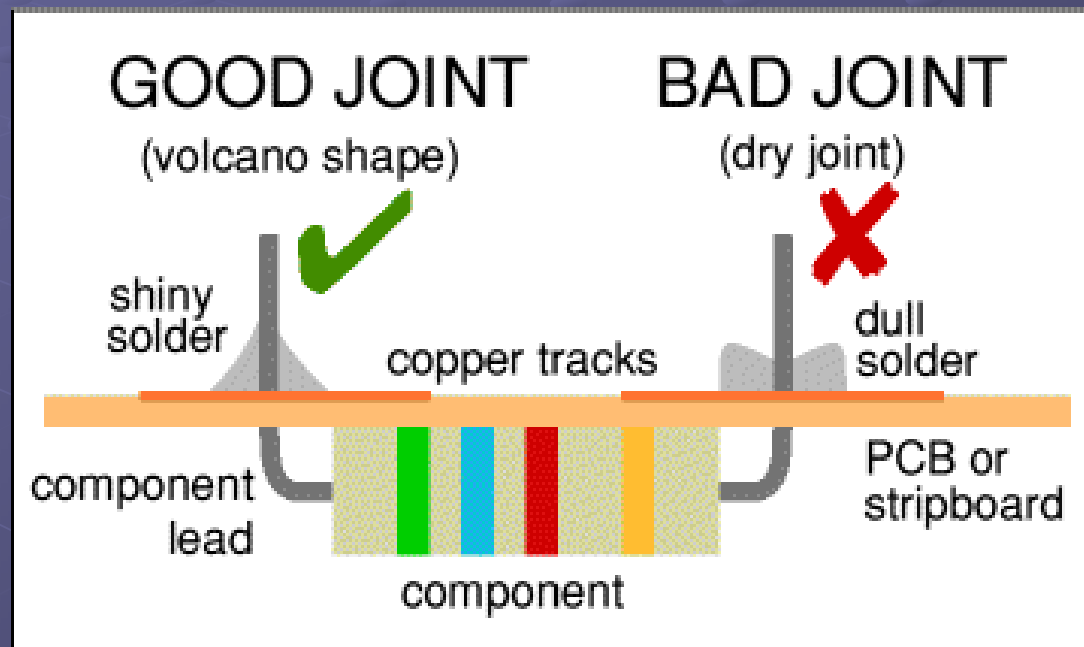

© Electronics Club, reproduced with permission.

Soldering – Dry Joints

- If the solder fails to wet the various metals a dry joint may occur.
- It is also used to mean any sort of unsatisfactorily soldered joint.
- Dry Joints are liable to fail electrically.
- Look for a shiny “Volcano” **with no gaps, and no solder bridges.**

Soldering – Safety Precautions (from the Electronics Club)

- Never touch the tip of the soldering iron.
- avoid touching the mains flex with the tip of the iron.
- Always return the soldering iron to its stand when not in use.
- Avoid breathing the fumes, if possible
Work in a well-ventilated area.
- **Wash your hands after using solder
(especially leaded solder).**

Soldering – Preparing the Iron (from the Electronics Club)

- Place the soldering iron in its stand and plug in.
- Dampen the sponge in the stand (damp, not dripping wet).
- Wait for the soldering iron to warm up.
- Wipe the tip of the iron on the damp sponge.
This cleans the tip; if it “sizzles” the iron is hot.
- Melt a little solder on the tip of the iron, if it does not melt the iron is not hot enough.

Starting to Solder

(from the Electronics Club)

- Hold the soldering iron like a pen, **near the base (but not on the heated part!)**.
- Touch both the component lead and the PCB for a few seconds (count 1, 2, 3 or 1, 2, 3, 4, 5)
- Then feed a little solder onto the joint until it forms a “Volcano”.
- Remove the solder & iron, keeping the joint still.
- Allow a few seconds to cool before you move the circuit board.
- Inspect the joint closely. If not right, reheat & add more solder.

If you do get burnt

- **Immediately cool** the affected area **under** gently running **cold water**.
- Keep in the cold water for 5-15 minutes
- If ice is available use it, but do not delay the initial cooling with cold water.
- **Do NOT apply any creams or ointments.**
- Seek medical attention if the burn covers an area bigger than your hand.

Soldering Electronic Kits

- Start with components that lie flattest
- MERG Bending Jig is useful
- Cut excess wire, possibly keeping them for wire links in later kits. Cut the wire before soldering (side cutters used at an angle) – makes it faster to solder as there is less of a heatsink (also recommended industrially as the cut end is covered with solder).

How to Solder Electronic Kits (2)

- Bend wires straight instead of at an angle
 - easy to see the “volcano”
 - Easier to unsolder
 - But component could drop out ...
- Useful aid is 2 clamps & a piece of hardboard
- Do **NOT** clamp multipin headers in a plastic base.



How to Solder Electronic Kits (3)

- For multipin components, solder one pin at each end, check it lies flat before completing the soldering. If not flat, touch soldered pin with hot iron while pushing down.

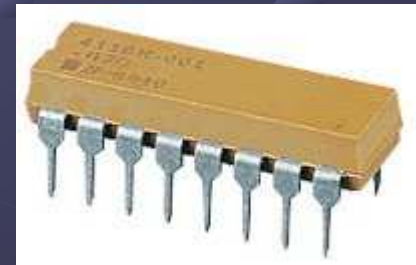
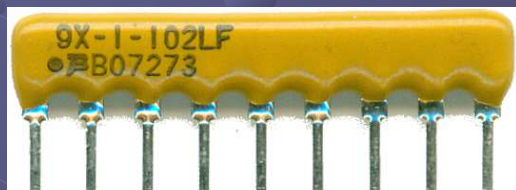

- (What are these things?)

After Soldering PCBs

After soldering (even if no extra flux has been added) there will be flux residues.

Remove these with –

- Ultrasonic bath & IPA
- meths & toothbrush (first application may leave a sticky residue, a second wipe with clean meths clears this).

Some use 50:50 meths:water.



Component Recognition & Circuit Simulation

Component Recognition

- “Circuit Boards look to me like a mad mixture of tiny Liquorice Allsorts and Dolly Mixtures and the sight of folks making up boards to their design fills me with admiration” John de Frassiniet, see

www.009.cd2.com/DCC.htm



What are the Liquorice Allsorts in Kits?

- PCB
- Resistors
- Capacitors
- Diodes and LEDs
- Voltage Regulators
- Resonators
- Relays
- Transistors
- PICs and other ICs (integrated circuits)
- Switches and connectors



PCB (Printed Circuit Board)

- Can be single or double sided in MERG kits.
- Single sided will have wire links where tracks have to cross.

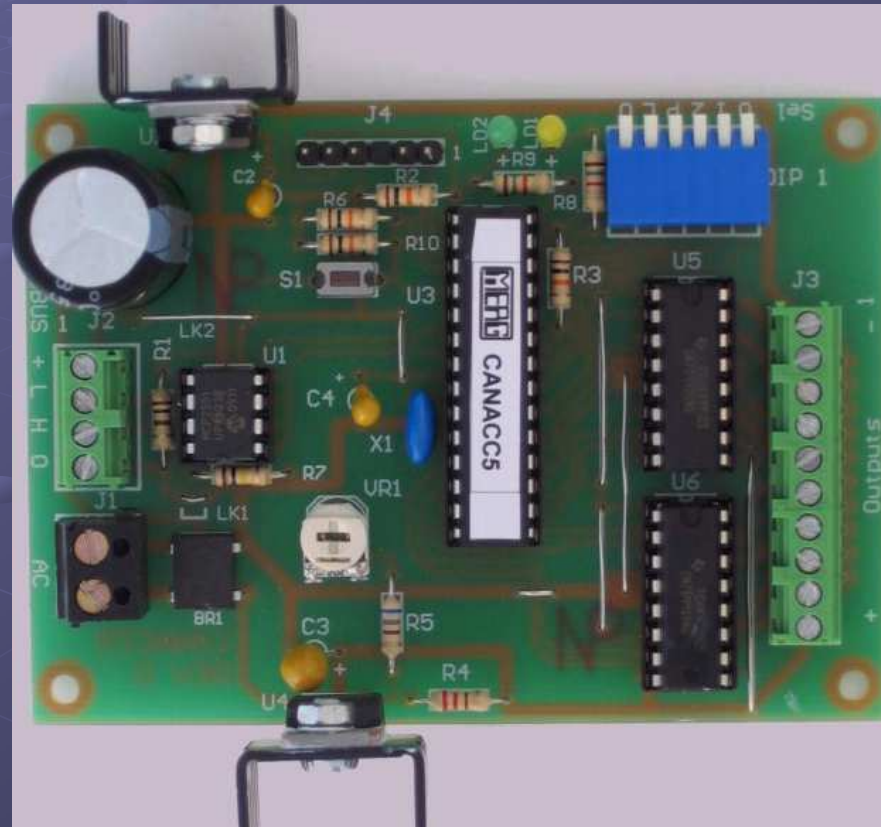

Double sided PCBs.

- Normally all components still soldered from one side.
- No need for wire links (unless they replace “removable” links)
- Can have a large “ground plane”
- PTH (Plated Through Holes) do make it harder to remove components.
- Becoming more popular in MERG.

Resistors

- Can reduce the Voltage applied to other component(s).
- Can limit the electrical current flowing through other component(s).
- Also available Variable Resistors

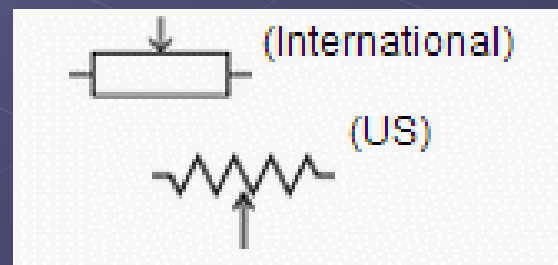
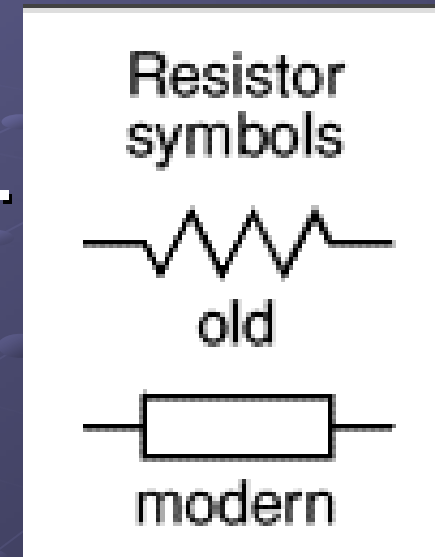

Resistors (2)

- Resistance is measured in Ohms (Ω),
- The “modern” way is to replace the decimal point with a letter.
 - 1R5 = 1.5 Ohms
 - 1K5 = 1.5 KilOhms = 1,500 Ohms
 - 1M5 = 1.5 MOhms = 1,500,000 Ohms
- N.B. R47 is **NOT** the same as 47R
- Resistors are **NOT** polarised.

Resistors (3)

- Generally the size of a resistor depends on its power rating, not its value.
- Values are shown via 4 or 5 colour bands
- To check use either
 - Catalogs
 - A Meter
 - CreateResistor from MERG public webpages
 - <http://www.merg.org.uk/resistor/index.htm>

N.B. the no. of bands is important

- The last band denotes Tolerance
- The other bands give the value, e.g. 100R
 - 4 band 10% = brown/black/brown/silver
 - 5 band 2% = brown/black/black/black/red
- brown/black/black...could be
 - 10R if 4 band
 - 100R if 5 band
- So be careful if 4 band is documented, but the kit has a 5 band resistor.

Resistor Colour Codes

- There are various mnemonics to help remember the colours. I like this one -

Bye Bye Rosie Off You Goto
Blackpool Via* Great Western

*V=Violet=Purple.

Black
Brown
Red
Orange
Yellow
Green
Blue
Purple
Grey
White

CreateResistor Program

Colour Bands not used below 1 Ohm.

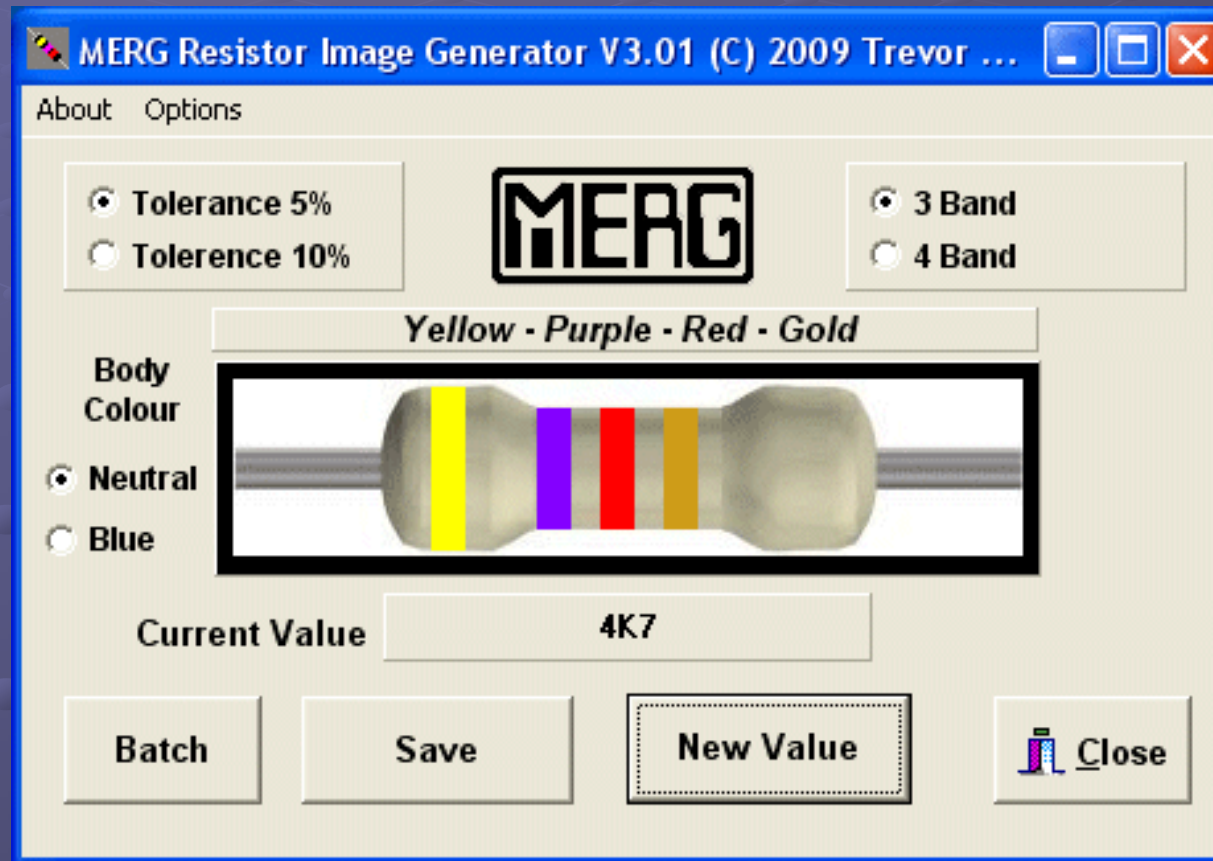

Preferred Resistor Values

- minimizes the number of different sizes that need to be manufactured or kept in stock.
- Various ranges E12 (10%), E24 (5%) etc.
- when some random value is replaced with the nearest preferred number, the maximum error will be on the order of 10% for E12 etc.
- chosen so the different sizes end up roughly equally spaced on a logarithmic scale.
- They are “equally spaced” just like the notes on a (correctly) tuned piano.

Preferred Resistor Values

Example E12 has 12 values

10, 12, 15, 18, 22, 27, 33, 39, 47, 56, 68, 82

Then 100, 120 etc.

Each value $\sim 1.2 \times$ previous

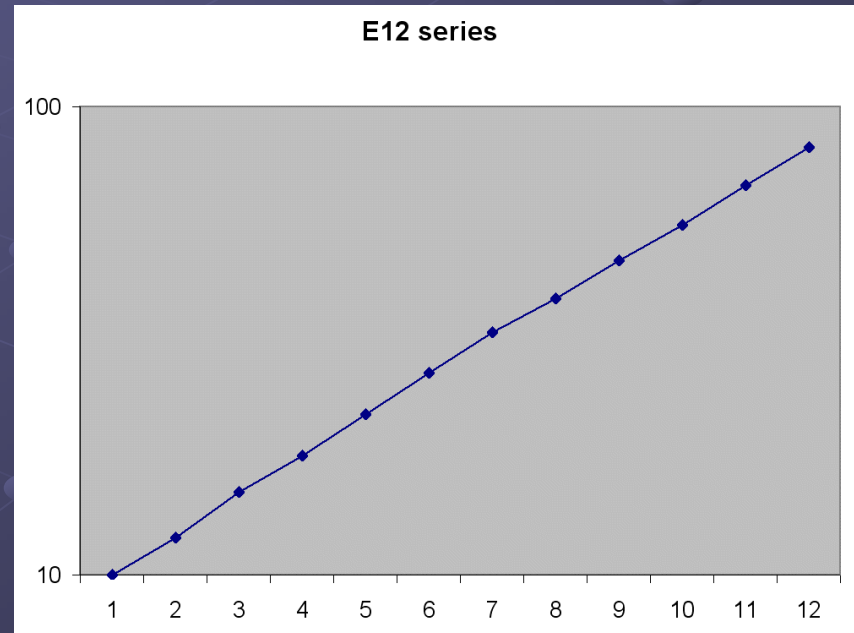
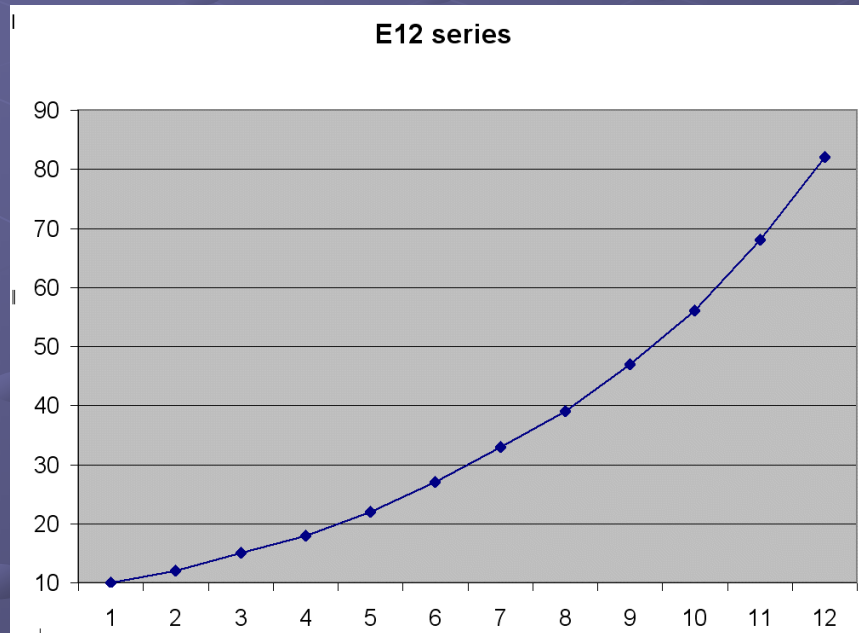

Basic Mathematics

- Ohms Law, Volts, Amperes & Ohms

$$V = I \times R$$

- Power (Watts)

$$W = I \times V$$

- Resistors in series

$$R_{\text{total}} = R1 + R2 (+ R3 \dots)$$

- Equation for LEDs

$$R = (V_s - V_f) / I_f$$

Fundamentals

- Circuits are read as if flow is positive e.g. from the +ve battery terminal to ground.
- In fact it's the other way round (electrons).
- A circuit simulator is very useful e.g. Crocodile Clips as used here. See the Member's Software Download Page

<http://merg.org.uk/forum/merg-software.php>

(Note comment for Windows 64 bit)

Circuit Simulation (MISD1)

- Voltmeters just need probes.
- Ammeters need to be inserted in circuit (and different test lead socket)
- Ohmmeters need to be applied with the component out of circuit.

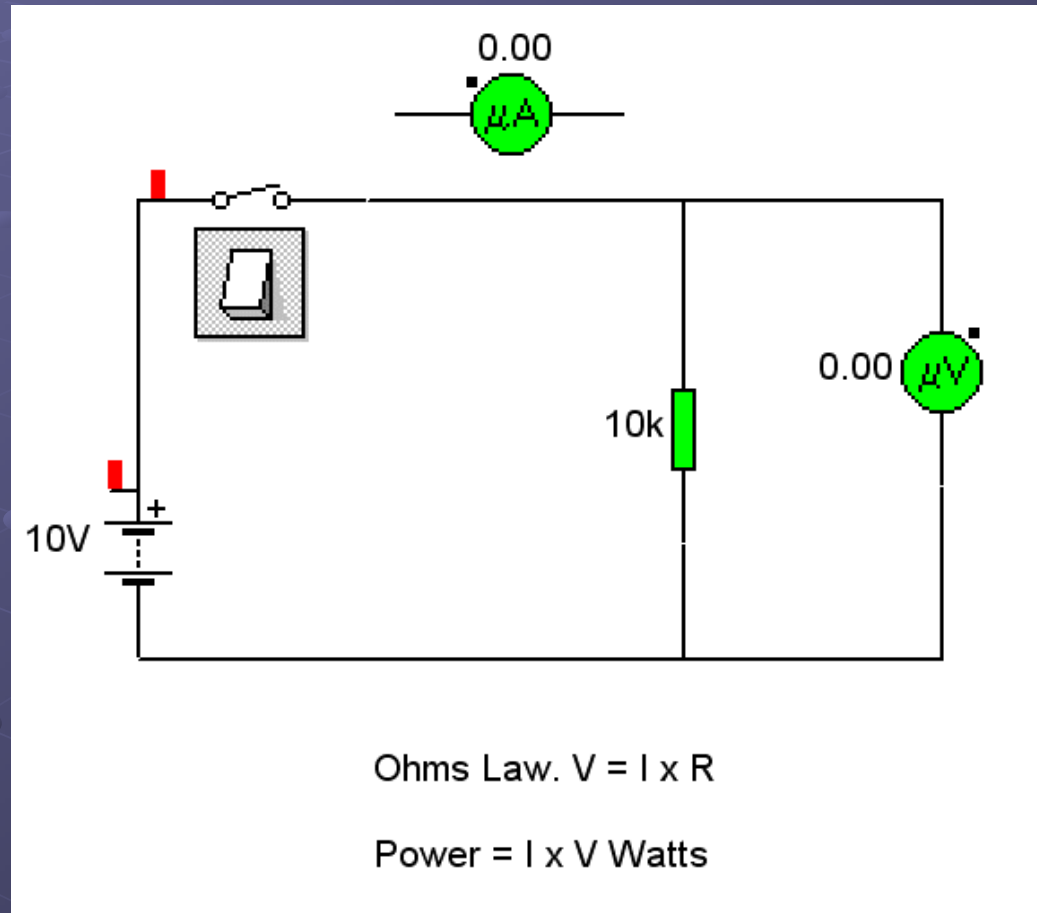

Using an Ohmmeter

- Ohmmeters work by passing a small current and measuring the Voltage.
- The component **MUST** be isolated from the circuit. Otherwise -
 - a false reading may be given.
 - possibly the meter will be damaged.
 - possibly other components in the circuit will be damaged by the applied Voltage (perhaps applied with an inappropriate polarity) .

Using a Dedicated tester

- Rapid (85-2017), £92, good for SM with optional tweezers.



- Ebay from £9.



Resistor Ladder (MISD2)

Resistors in ratio 4:1

So Voltages are

4V & 1V (Ohms Law!)

$$V = I \times R$$

With preferred values

200R -> 220R

50R -> 47R

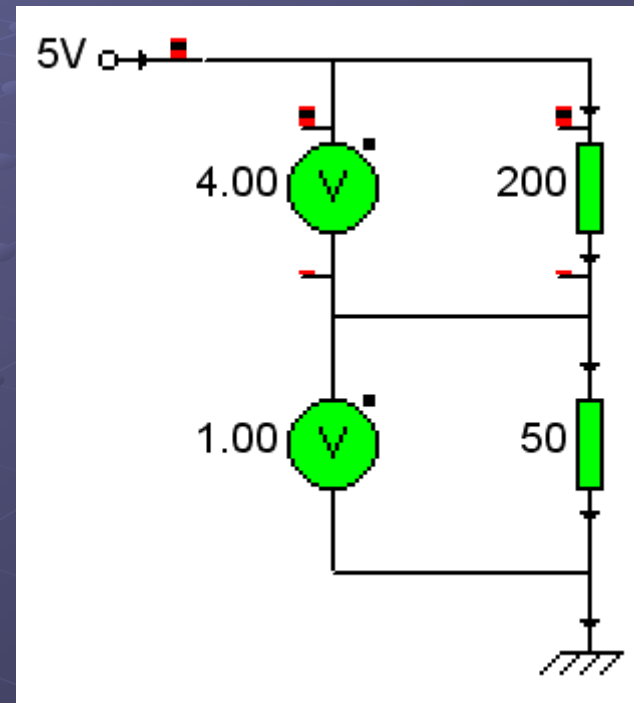

Resistor Ladder

To understand this, use Ohm's law twice

- First

- total $R = 200 + 50 = 250$ Ohms
- So current $I = V/R = 5/250 = 20$ milliAmps

- Second, use this across each resistor

1. $V = I * R = 20 \text{ mA} * 200 \text{ Ohms} = 4 \text{ Volts}$
2. $V = I * R = 20 \text{ mA} * 50 \text{ Ohms} = 1 \text{ Volt}$

N.B. The **ratio** of resistors is important (for the Voltages), not their **actual values**

SIL (Single In-Line) Resistor Arrays,

2 types, e.g.

- 9 pin (polarised)



- 8 pin (non polarised)



- align with dot/chamfer

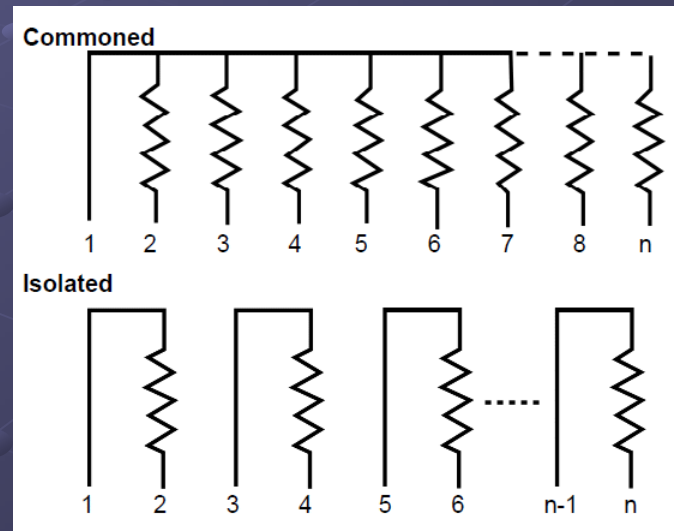
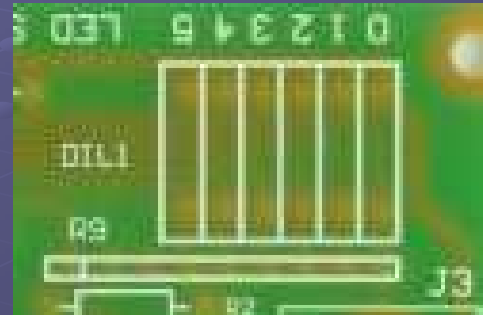

DIL (Dual In-Line) Resistor Arrays

These are not polarised

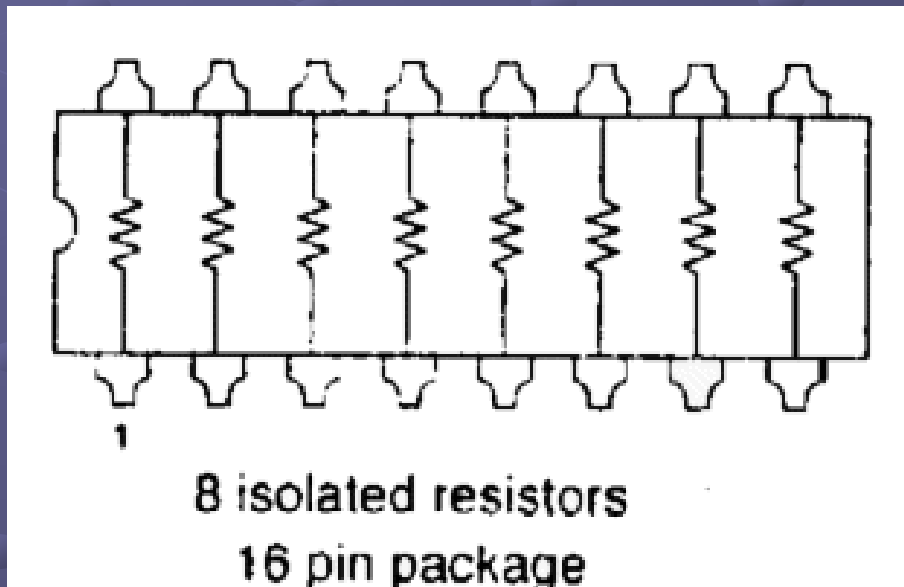
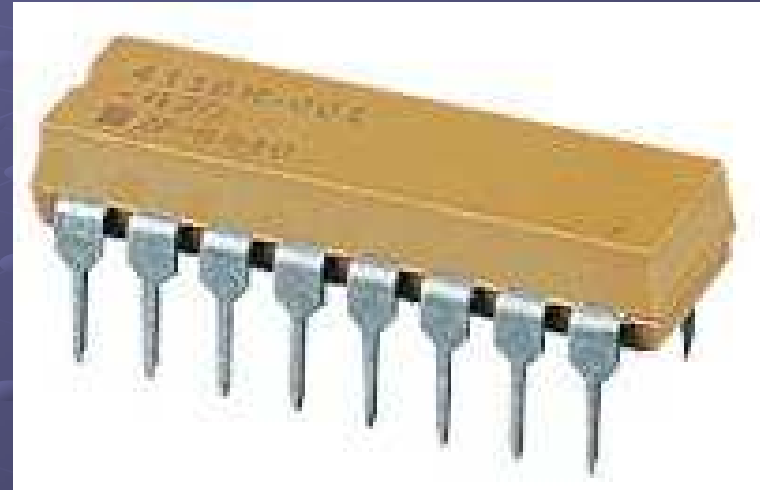

Potentiometers & Variable Resistors

- A Potentiometer (a.k.a. “pot”) is a 3 terminal resistor with a sliding contact that forms an adjustable Voltage divider.
- If only two terminals are used (one end and the wiper) it acts as a variable resistor

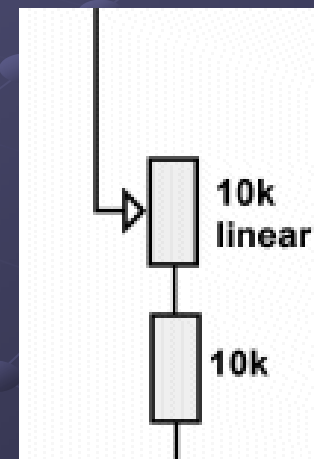
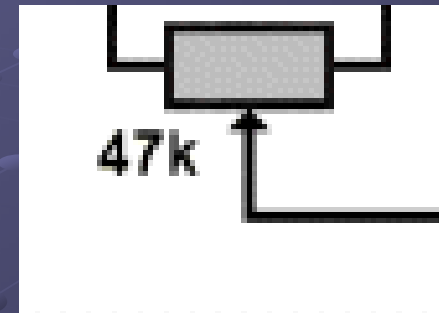
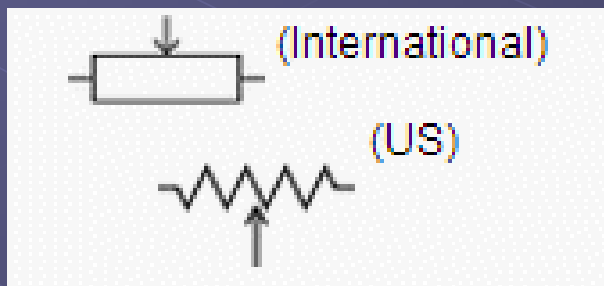

Capacitors

From <http://www.kpsec.freeuk.com/>

- Capacitors store electric charge.
- It takes time to charge/discharge, so used with resistors in timing circuits
- used to smooth varying DC supplies by acting as a reservoir of charge.
- Also used to remove noise (if $< 1 \mu\text{F}$)
- used in filter circuits because they easily pass AC (changing) signals but block DC (constant) signals.

The size depends (approximately) on its value.

Capacitors

Unit of Capacitance is the Farad

● Most capacitors in MERG kits have small values

- 1 uF or 1 μ F = 1 micro Farad (1 millionth)
- 1 nF = 1 nanoFarad (1 thousand millionth)
- 1 pF = 1 picoFarad (1 million millionth)

So

$$1\,000\,000\ \mu\text{F} = 1\text{F}$$

$$1000\ \text{nF} = 1\ \mu\text{F} \text{ and so } 100\ \text{nF} = 0.1\ \mu\text{F}$$

$$1000\ \text{pF} = 1\ \text{nF}$$

Capacitors

- Capacitors may also have a Voltage rating. This should not be exceeded.
- Examples 16V & 25V



Capacitors

- May be axial (lead each end)



- or radial
(leads both at same end)



- May be polarised (Electrolytic or Tantalum bead) or unpolarised (ceramic)
- Values (approx): ceramic < Tantalum < Electrolytic.
- There are other types, but these are the ones in most MERG kits.

Polarised Capacitors

- MERG kits show “+” for the positive side
- Electrolytic, a stripe is shown on the negative side.
- Tantalum Bead, marked with a “+”.
- Positive lead is longest.

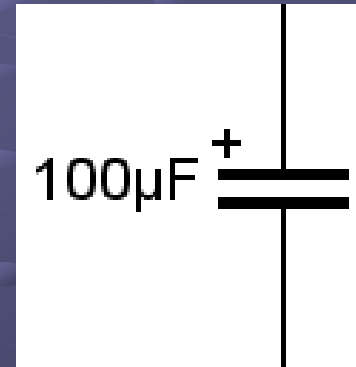

Circuit Simulation (MISD3)

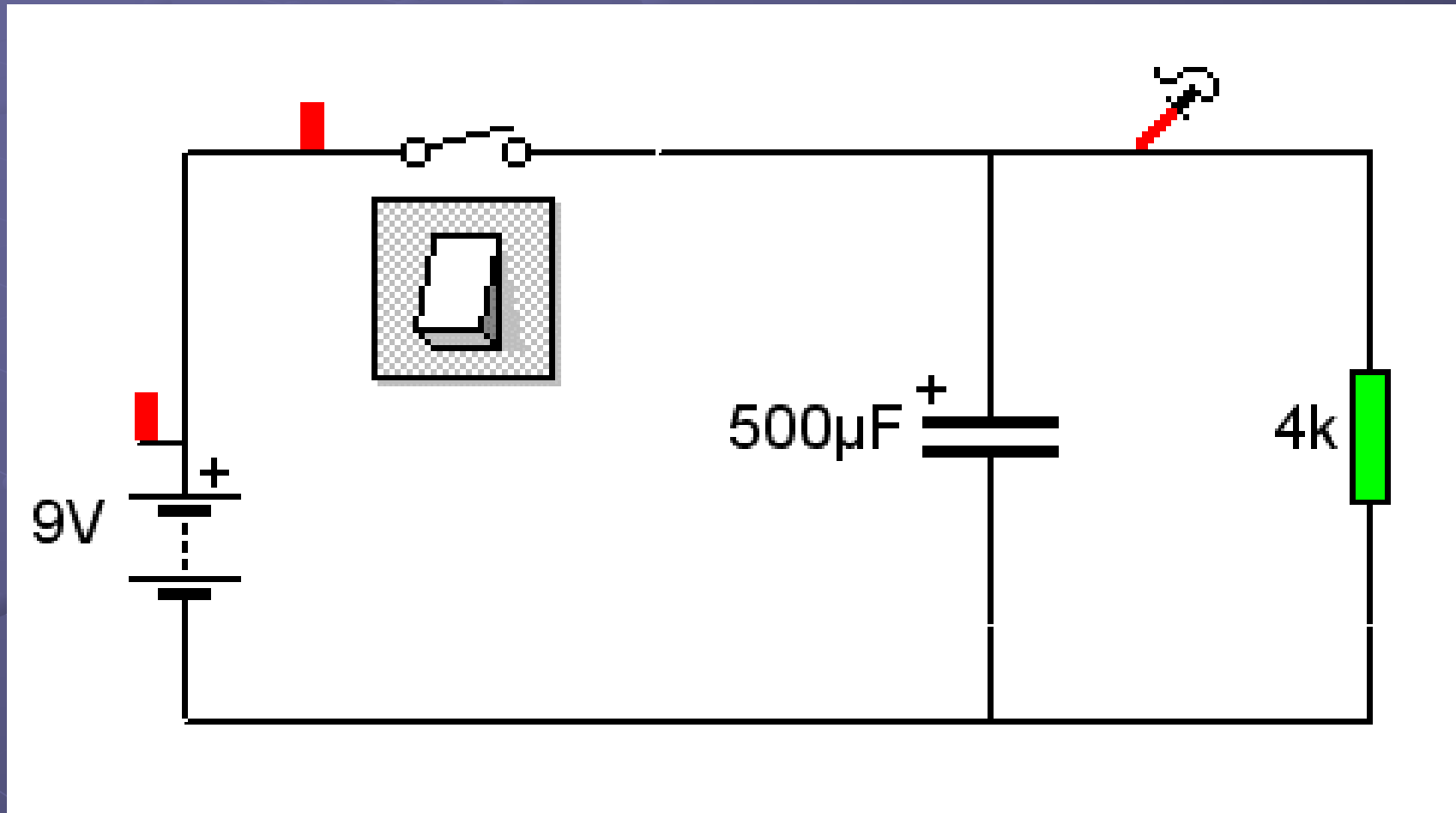

Diodes and LEDs

- Diodes allow electricity to flow in only one direction. Useful for Bridge Rectifiers.
- There will be a Volts drop of about 0.6 – 0.7 Volts across a conducting diode.
- Diodes are polarised, band marks “-” = “k” = Cathode.

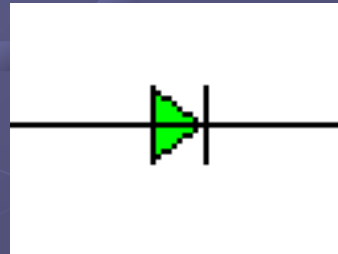

- The size of a diode depends on its current capacity

Diodes

Typical Diodes in MERG kits

● Signal Diodes

- 1N4148 (high speed switching), 0.1 Amps

● Rectifier Diodes

- 1N4001 (1A 50V), 1N4002, (1A 100V) etc.

● Schottky Diodes

- 1N5819 (Low Voltage drop ~ 0.2 Volts)

LEDs (Light Emitting Diodes) -

- illuminate when current flows.
- are useful for Control Panels, Coach Lighting etc., more on LEDs later.
- are polarised, longer lead is “+” = Anode (or a bar is shown at the Cathode).
- Size depends on usage!

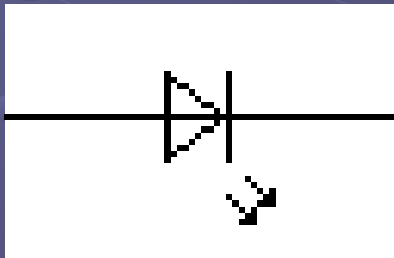

- More later ...

How to Solder – Recap

- Place the iron on the PCB and touch the component lead, so both get hot.
- Count 1,2,3... then feed in solder.
- When a “volcano” has formed remove iron but keep components still.

**Demonstration of soldering
And desoldering**

How to Solder Wires

PRACTICAL (1)

Joining two wires together – bulge in middle of heatshrink stops it moving.



When complete try the “pull test” and check for electrical continuity.

How to Solder Wires

PRACTICAL (2)

- Joining a wire to a PCB. When complete try the “pull test” to ensure the pads on the PCB have not lifted.
- Soldering a resistor/diode (use the “bending jig”) to a PCB.

Understanding Schematics

- If wires are joined they are often shown as a “blob”
- Wires crossing do not normally join
- However different designers have different conventions!

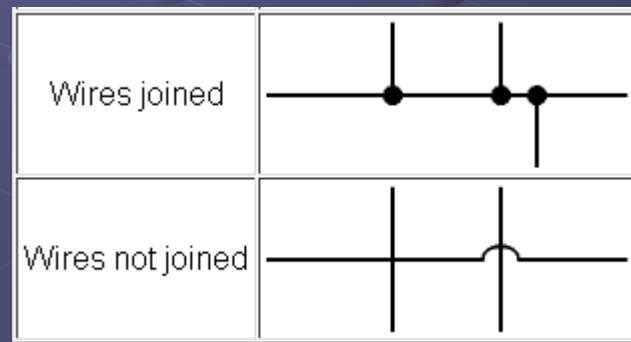

Schematics

http://www.rapidtables.com/electric/electrical_symbols.htm

for a list of circuit symbols

Extract from MERG
Kit 56, DTC

Compare with next
slide

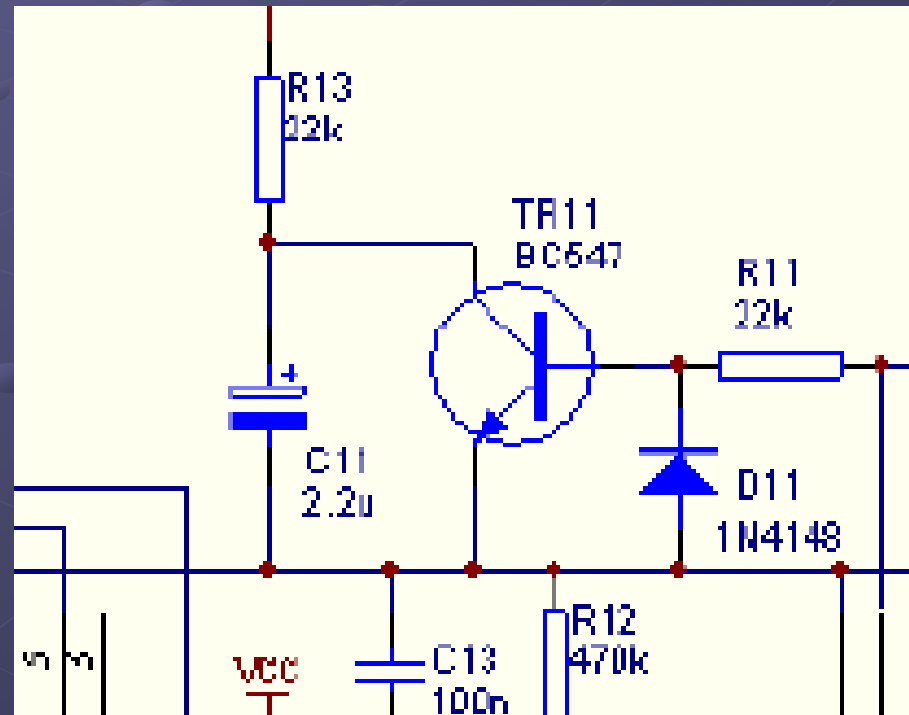

Bridge Rectifier

Typical use in a MERG Kit

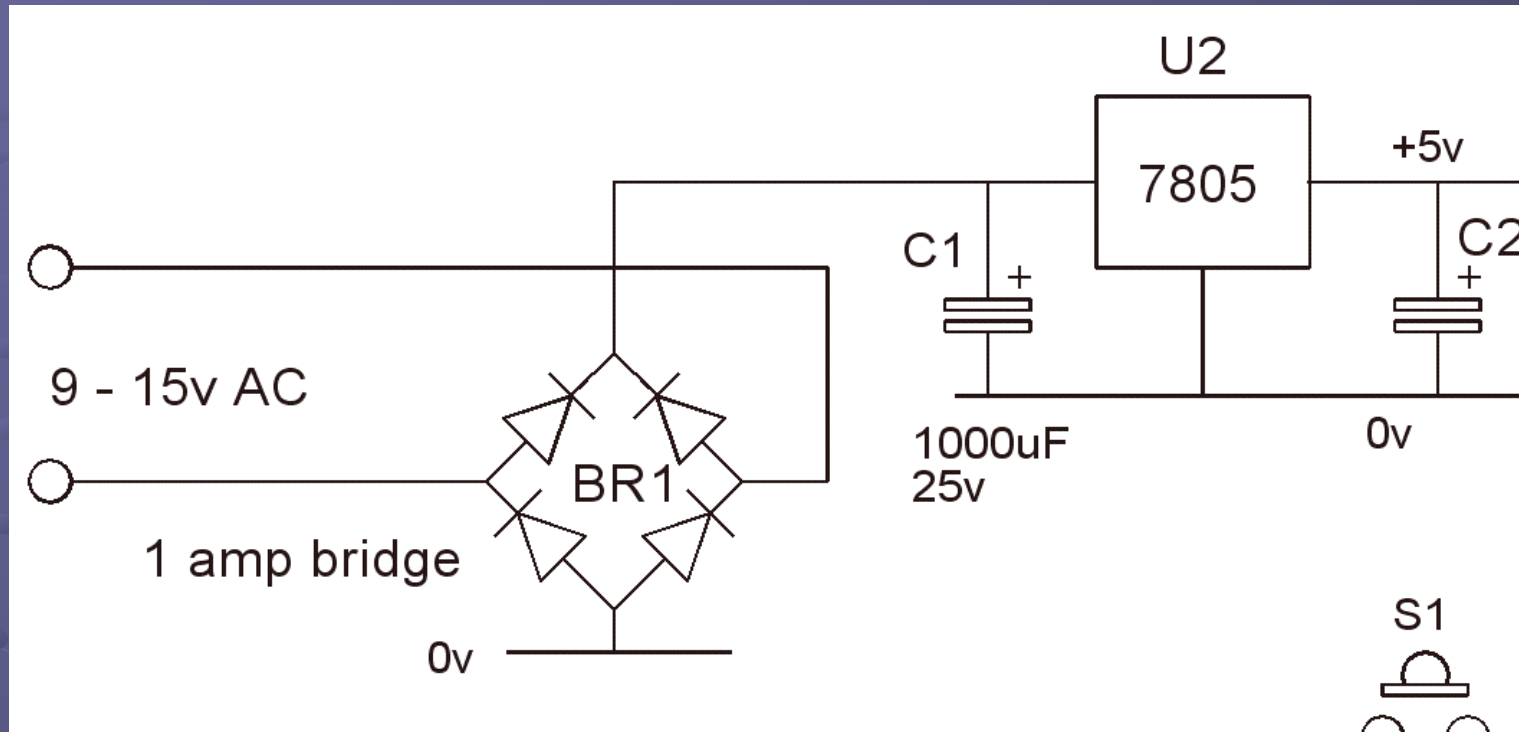

What happens if DC is applied? For animation, see <http://electronicsclub.info/powersupplies.htm>

Bridge Rectifier

- AC expressed as root mean square of the wave form i.e. the peak Voltage is 1.4 times input.
- So 16 Volts AC has a peak Voltage of 22.4 volts.
- Whether we use AC or DC Voltage as input, there will be 2 diode Voltage drops in the circuit.
- So for 16V AC, the Voltage across the capacitor is $22.4 - 1.2 = 21.2$ volts, and the Voltage rating of the capacitor must be above this.
- N.B. cannot expect 16V DC to work if AC suggested.

Circuit Simulation (MISD4)

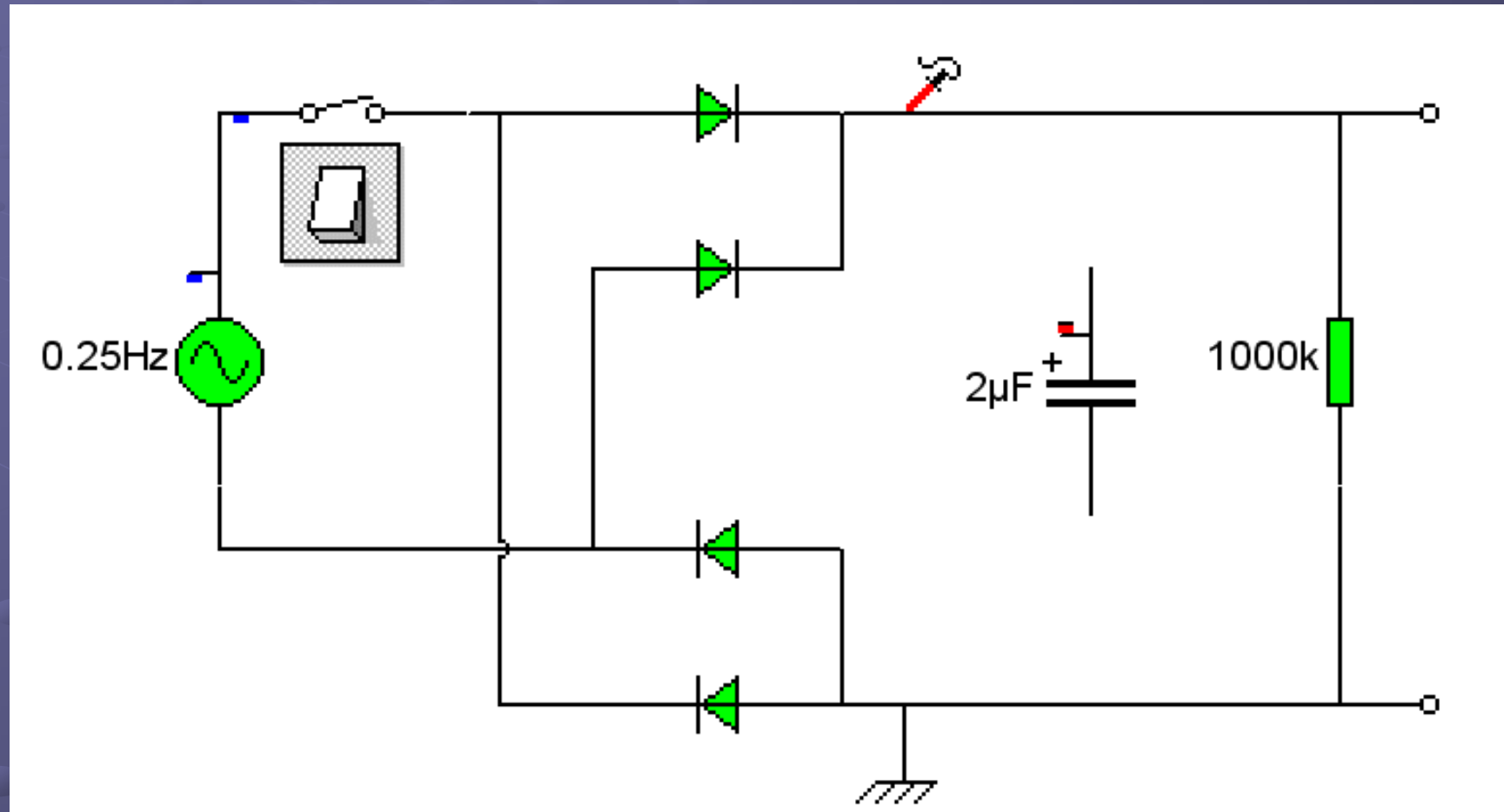

Voltage Regulators – Two types

- Fixed Voltage e.g. 7805 (5 Volts)
- Variable Voltage, adjusted via trimpot

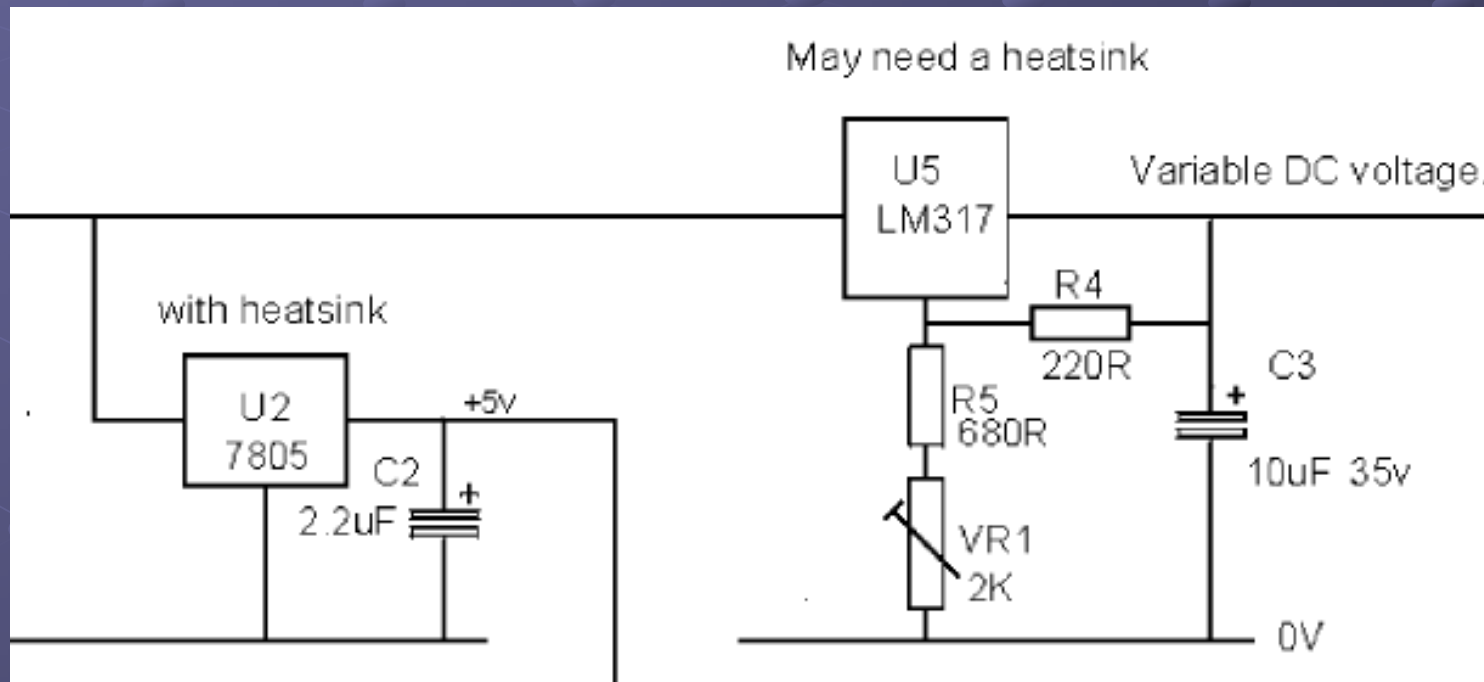

Voltage Regulators

- May need Heatsink
- Ideally attach with self-adhesive heatsink pads (38-0428)

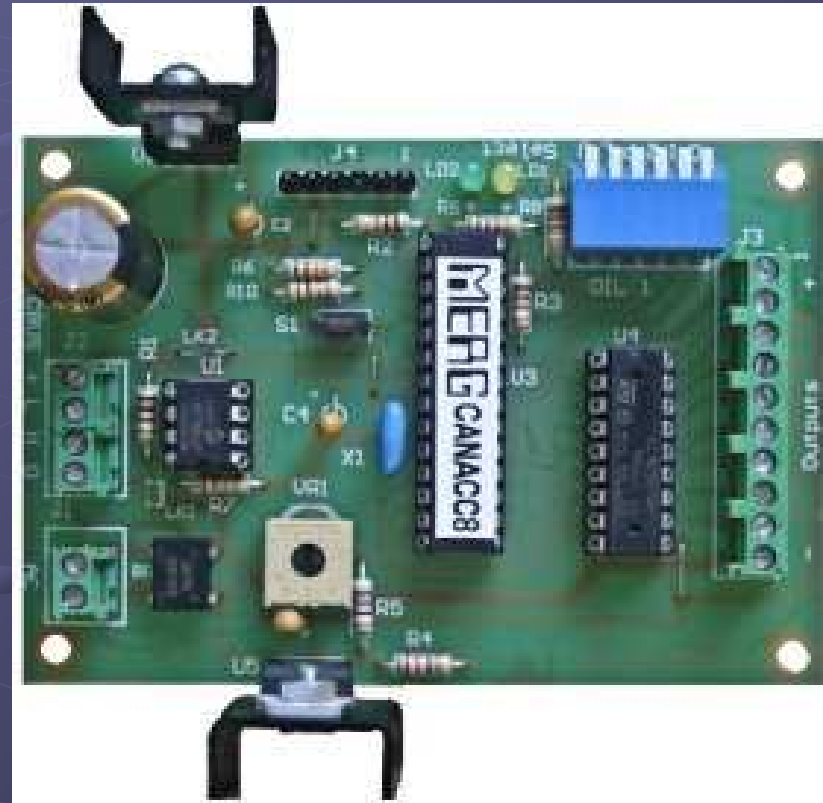

Resonators

- A device used to produce an oscillation of a specific frequency, primarily for use as the clock signal for digital circuits.
- The type with 3 legs or leads (in MERG kits) can be inserted either way round.

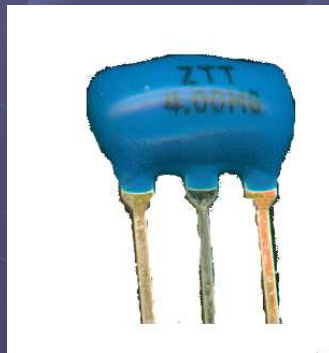

Transistors

(all you really need to know)

- They exist as NPN & PNP types (refers to layers of semiconductors used in fabrication).
- Most are NPN, PNP is rarely used to-day.
- They have 3 “legs”
 - Collector
 - Emitter
 - Base

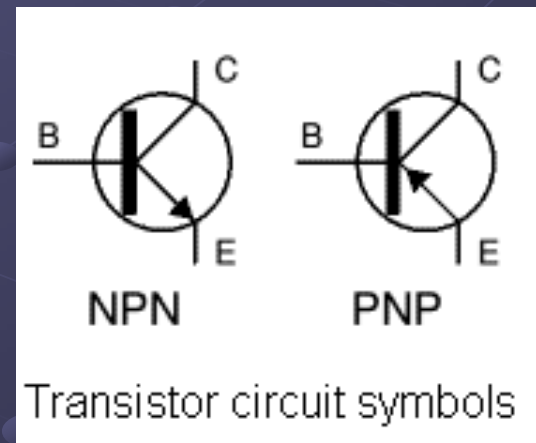

Transistors

More information for the curious

From <http://electronicsclub.info/transistorcircuits.htm>

A transistor may be used

- As a switch (fully on with maximum current, or fully off with no current)
- To amplify current (e.g. amplify small output current from a logic IC to operate a lamp, relay etc.)
- To amplify Voltage - a resistor converts changing current to changing Voltage.

See also MERG Journal Vol 48 No. 4 p j7+

D connectors

- Servo4 “connect probe to pin 5”. Where?
- Look at PCB & schematic, but beware top/bottom orientation.

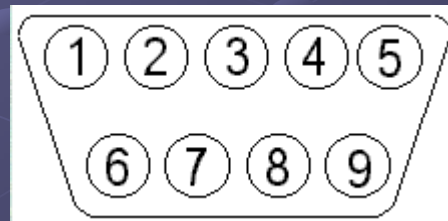
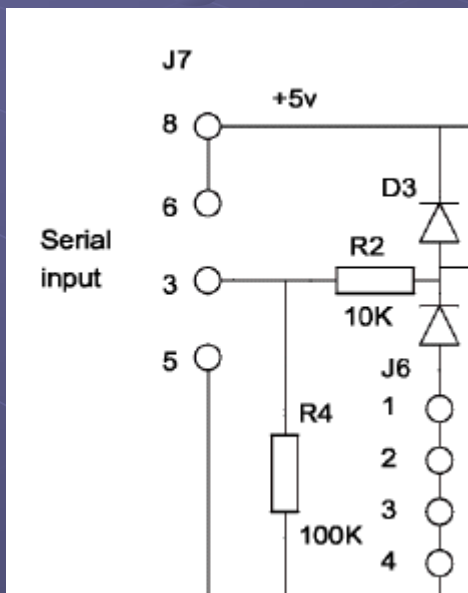

ICs (Integrated Circuits)

- Although looking like DIL resistor arrays, they are **polarised** with a “bite” at one end.
- Normally (in MERG kits) they are inserted into DIL IC sockets (also with “bites”)

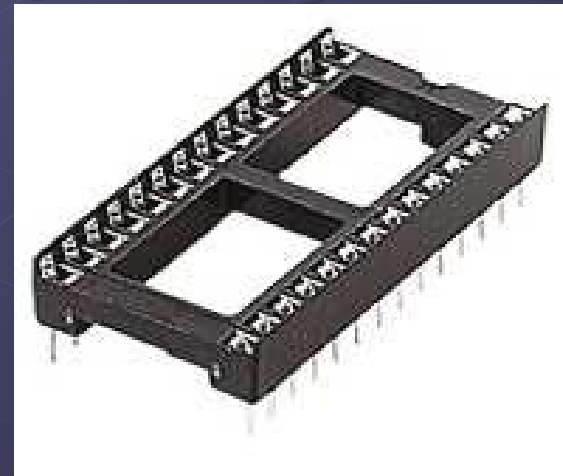
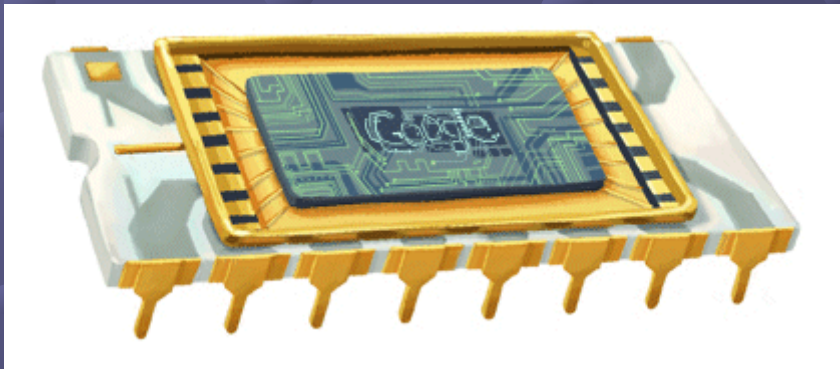

PICs

Programmable Integrated Circuit

- the most sophisticated ICs used in Kits.
- They need to be programmed - not trivial.
- For uploading PIC code use the MERG PICMasters service.
- The “Picaxe” system is suitable for home experimentation, see <http://www.picaxe.co.uk>

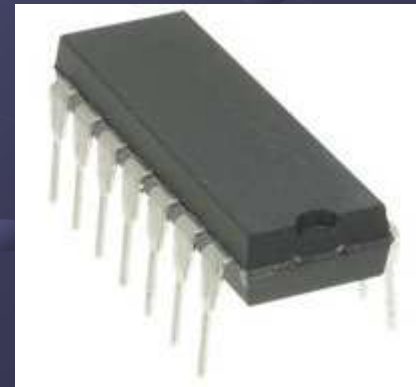

Inserting ICs

Try to avoid static build-up

- Keep the IC, the PCB & you at the same potential.
- if in doubt avoid synthetic fibres (clothes, chair covers) and consider an antistatic wrist strap (87-1282). See also MERG Journal Vol 48 No 4 p j10
- Need to bend the ICs legs before insertion
- either simply put the IC & ones fingers on a metal rule, or ...

Inserting ICs

- ... use an IC Straightener (22-0330)



Relays

are electrically operated switches

- Current flowing through the coil of the relay creates a magnetic field. This attracts a lever and changes the contacts.
- The coil current can be on or off so relays are double throw (changeover) switches (**No centre off!**)
- one circuit can switch a second (completely isolated) circuit. There is no electrical connection inside the relay between the two circuits.
- For example low Voltage can switch
 - 230V AC mains (High Voltage **&** AC).
 - DCC circuits.

Relays

- When a relay is switched off, a brief high Voltage is produced. Transistors and ICs must be protected from this via a diode connected 'backwards' across the relay coil.

Relays – Circuit Simulation (MISD5)

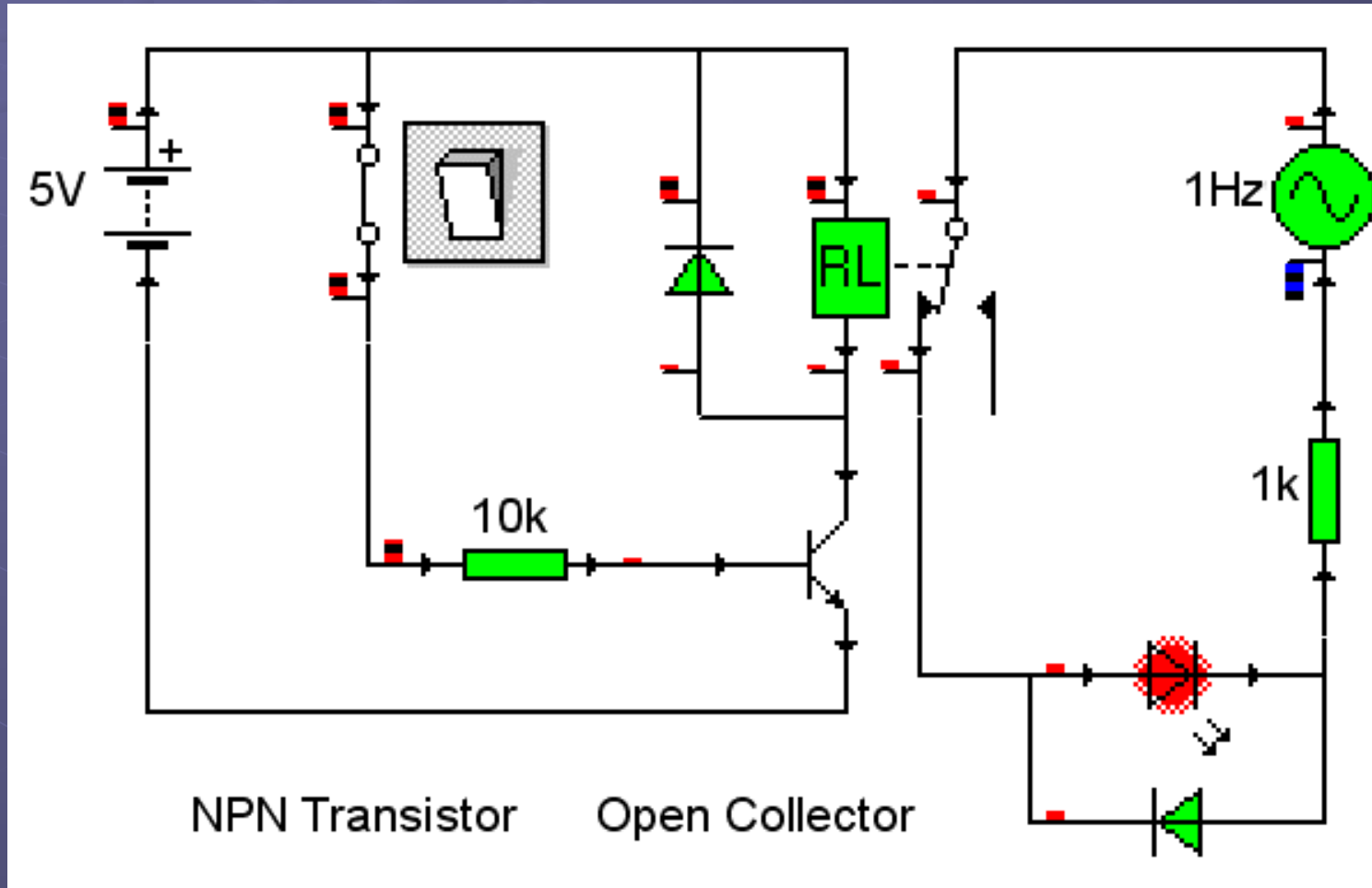

Relays

For an animation of a relay see

<http://electronicsclub.info/relays.htm>

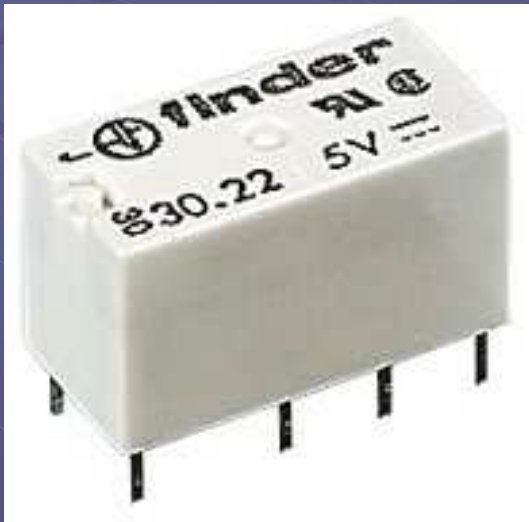

Switches

SPST, SPDT, DPST, DPDT etc.

We all know what a switch is, but what are these?

- **SP**/DP**** = Single/Double **Pole**
- ****ST/**DT** = Single/Double **Throw**
- Also available as centre off, biased etc.

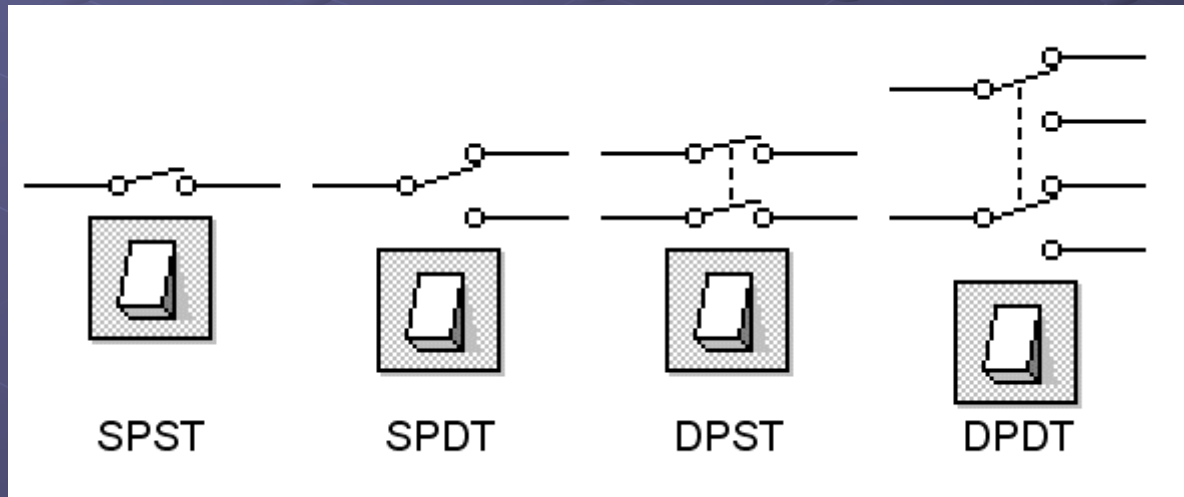

Other Switches

- Push Buttons, may be “push to make” or “push to break”

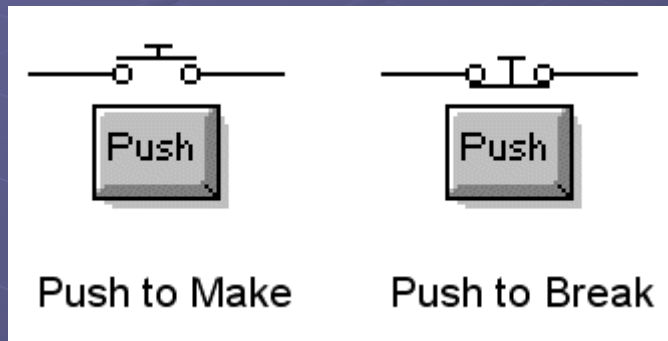

- DIL (Dual InLine), a way to combine several switches in a small space.

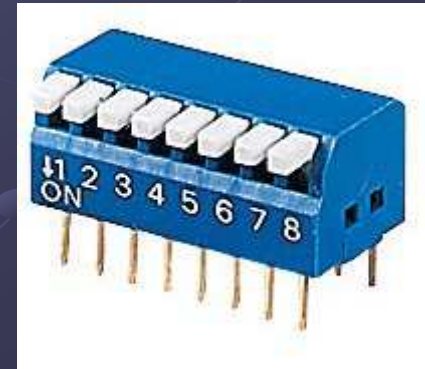

Switches

- Use of SPDT switches for Hall & Landing Lights (MISD5A).

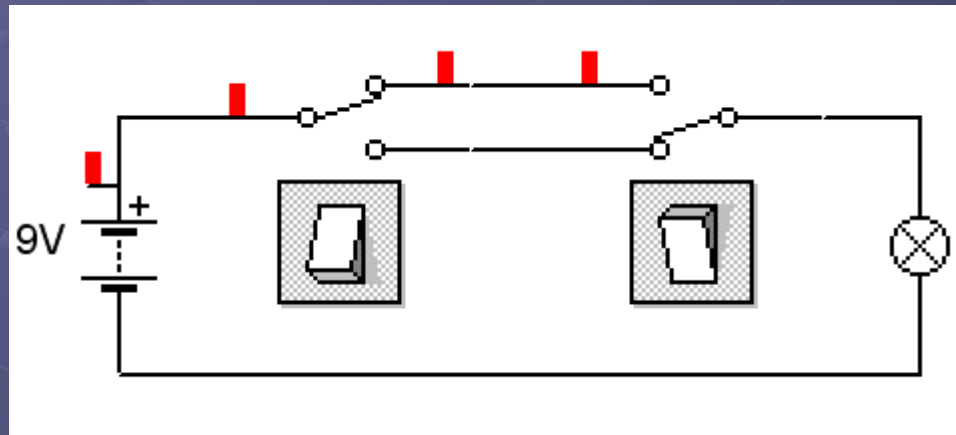

Component Recognition Can You See...

- 9 Resistors
- 1 Trimpot
- 4 Capacitors
- 1 Resonator
- 2 LEDs
- 2 Voltage Regulators
- Bridge Rectifier
- 4 ICs
- DIL Switch
- Terminal Blocks

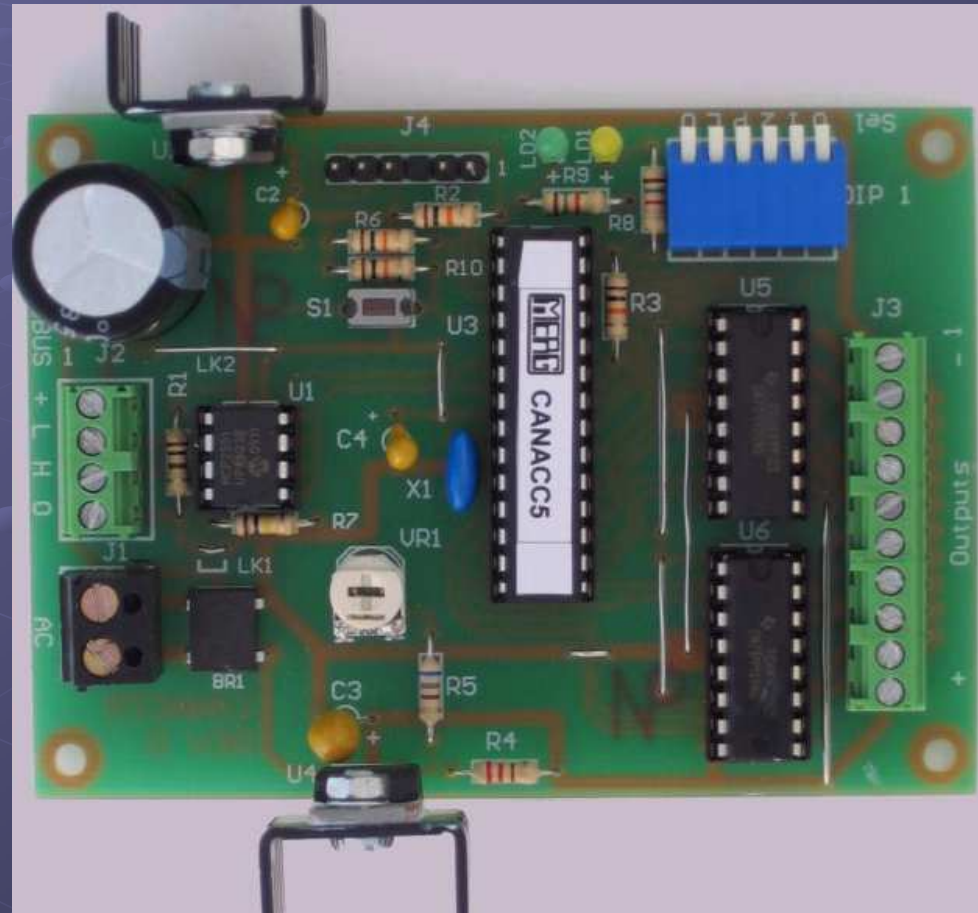

Recap – Soldering Electronic kits

You will need-

- A source of heat –use a soldering iron
- Solder – 18SWG 60/40 tin lead
- Flux – not required, its in the solder!
- Cleaning materials – not normally required, PCBs are plated (some Gold plated). If very dirty, use a fibreglass brush and/or isopropanol.
- (something to practise on?)

Recap – Ohm's Law

Ohms Law

$$V = I \times R$$

- V = Volts
- I = Amperes
- R = Ohms

V

I

R

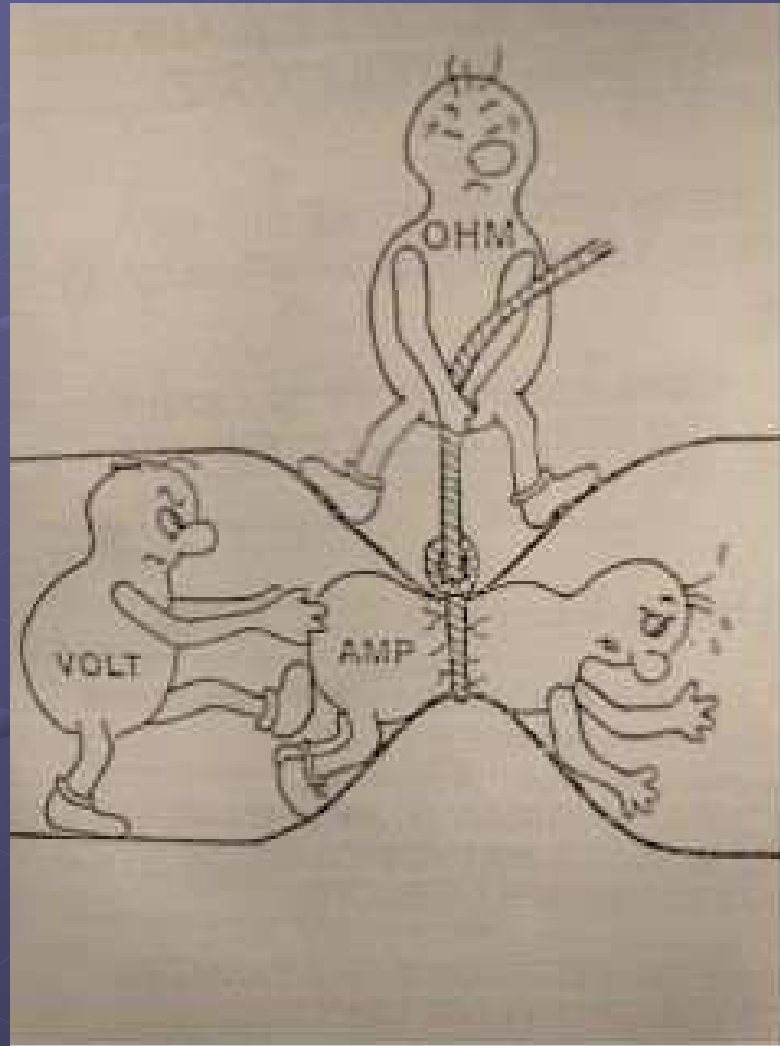

Electronics – the basics

- 80% of electronics can be worked out from Ohm's Law.
- Then consider the Volts drop across components (LED 1.6-2V, blue LED 4V, silicon diode 0.6-0.7V)
- 80% of the rest is about how long a capacitor takes to charge
- The other 4% is why people join MERG

Your First MERG Kit



Your First MERG Kit

Something simple is suggested e.g.

- Pocket Money Projects (simple, inexpensive)
- Kit 61: Gas Lamp Twinkler
- Kit 75: Servo4 point motor driver (perhaps with kit 681-690 Micro Servo Mounts for points, semaphore signals, gates etc.)
- Kit 74: Mark 2 relay kit

Constructing your first Kit

Fit wire links then resistors? But wire is not provided.

So, fit the resistors & use the clipped leads for wire links

Keep these for future kits.

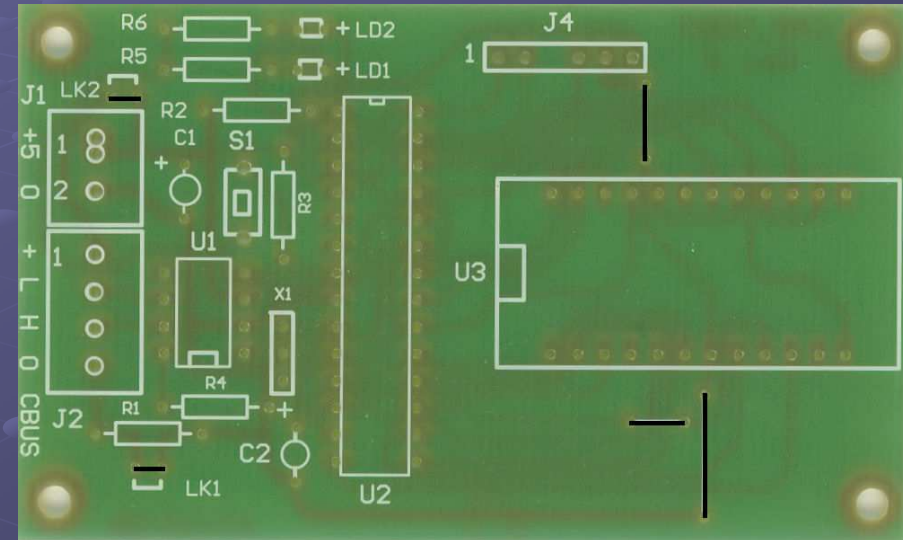

Track Testers

Proses £15

Train Tech £5



MERG PMP1 ~£1

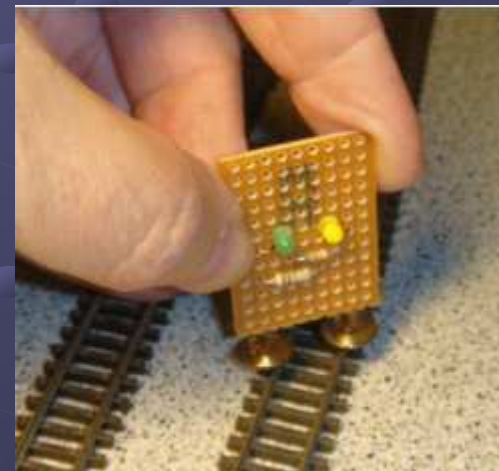

Constructing the Track tester

Components –

- 2 LEDs
- 2 resistors
- 1 PCB
- 1 Terminal Block
- 2 crocodile clips on leads

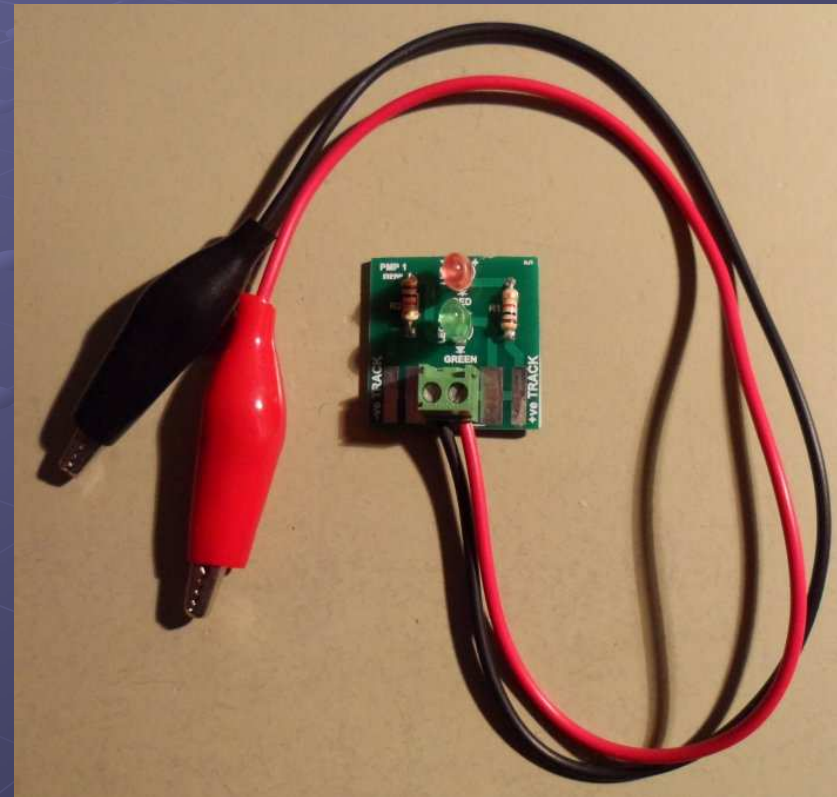

Constructing the Track tester

PRACTICAL (3)

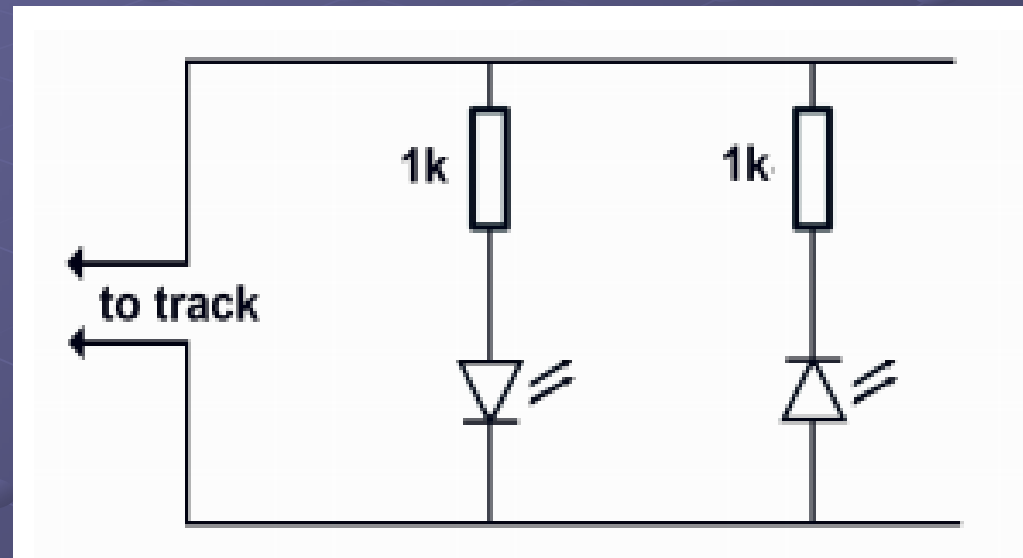



Fault Finding

Fault Finding

- Follow the tests in the building instructions
- Check the underside of the PCB for
 - Dry joints
 - Holes = components may be omitted or partially soldered.
- Check the polarity of
 - SIL Resistor Networks with one common (odd no. of legs)
 - LEDs & diodes
 - Capacitors (where applicable)



Fault Finding

- Learn to read the schematic.
- Is the input Voltage correct, and (if DC) the right way round?
- If an LED doesn't light, does it have a path? Is it the right way round?
- Have you chosen the right option (where that exists)?

Fault Finding

- Learn to use a Voltmeter.
- Easiest to test from the component side of the PCB, because you can find where you are.
- Also if you use the solder side it is easy to short two pads together.

Fault Finding

- If you had to modify the PCB (resolder a component, make cuts due to solder bridges etc.) check around your changes.
- If a PCB track has lifted, check if it has lost contact with adjacent tracks etc.

A lot of fault finding is just applying logic to what does not happen.

Fault Finding

Terminal Blocks (TBs)

- When checking Voltages in TBs, beware the screw may not make electrical contact. Best to insert a wire & check on that.
- Do not solder 2 wires together for fitting into a TB. The soft metal of the solder will cold flow and relax the hold from the screw terminal. So you get a loose connection which will make intermittent contact and give all sorts of errors.
- Better to use bootlace ferrules (can even use two wires in one ferrule).

Joining wires to terminal blocks

- The professional approach is to use Bootlace Ferrules in various sizes (e.g. 0.25mm² 33-1360) with crimping tool (85-0275).



Fault Finding

Stripboard (Veroboard)

Commonest faults are –

- links or components in wrong holes
- shorted strips (solder blobs)
- forgotten or wrong PCB tracks cut.
- Incomplete cuts.
- bad solder joints
- forgotten wire links.
- IC upside down

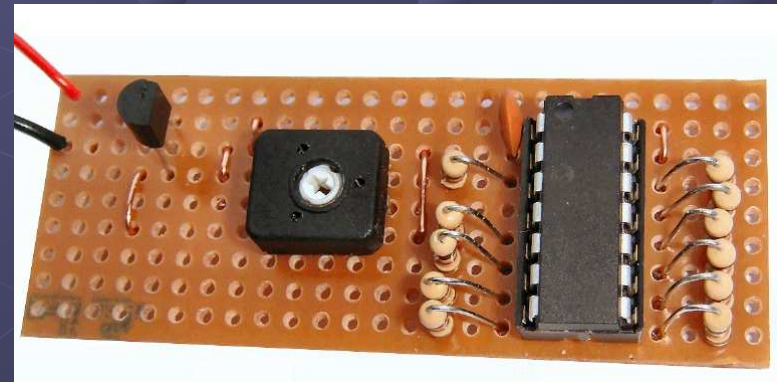



Baseboard Wiring

Baseboard Wiring

Baseboard Wiring involves

- Attaching cables, connectors, etc.
- Joining wires to-
 - Switches & Tag Strips
 - Terminal blocks
 - Other wires
 - Track
- Documenting it all!

Baseboard Wiring

Two things NOT recommended-

- Do NOT encase transformers in wooden boxes (use metal boxes, and earth them)
- Do **NOT** distribute Mains power on baseboards.



Attaching Cables to Baseboards

Various methods

- Low melt glue gun (87-3990 & glue sticks 87-4002)
- Cables ties/clips etc.
- Binding Combs



Mounting MERG Kits

- Most kits have provision for screws or M3 bolts.
- On some kits the spacers can be soldered to the PCB, so they don't drop off. Suitable metal spacers are 4mm tall (33-3611)
- If no solder pads, cut your own from plastic tube or use plastic spacers (33-3632) and super-glue them.
- Useful top - paint the underside of the baseboard white.



Mounting MERG Kits

- If there are no mounting holes, use slots in pieces of wood.

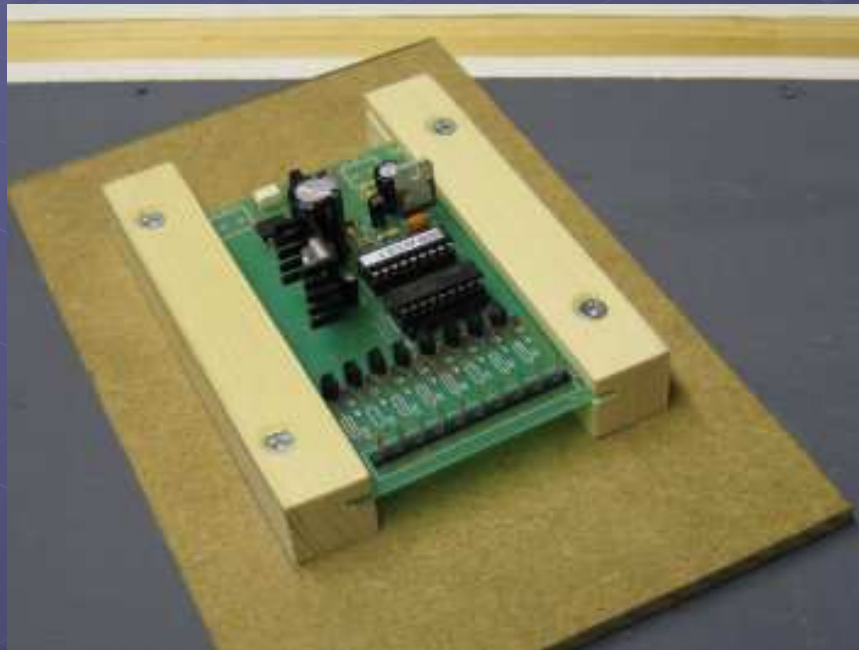

Joining wires to switches, tag strips

Need

- Strong mechanical joint
- Good electrical continuity
- Absence of bare wires (danger of shorting)

When Soldering, either

- bend wire over tag (harder to remove)

or

- Hold in place (other wires may come off)

Joining wires to terminal blocks

- Ideally do not solder, let the stranded wire compress.
- Avoid stray “whiskers”
- For 2 wires, use 3-way terminal blocks (2 screws so does not rotate)

BUT what if there are several wires to connect?

- If all the same size, twist together
- If different sizes, maybe solder together
- Consider other ways e.g. more terminal blocks, tag strips etc.

Terminal Blocks ...

...can also be used to allow a quick & inexpensive way to isolate parts of a layout in case of shorts.

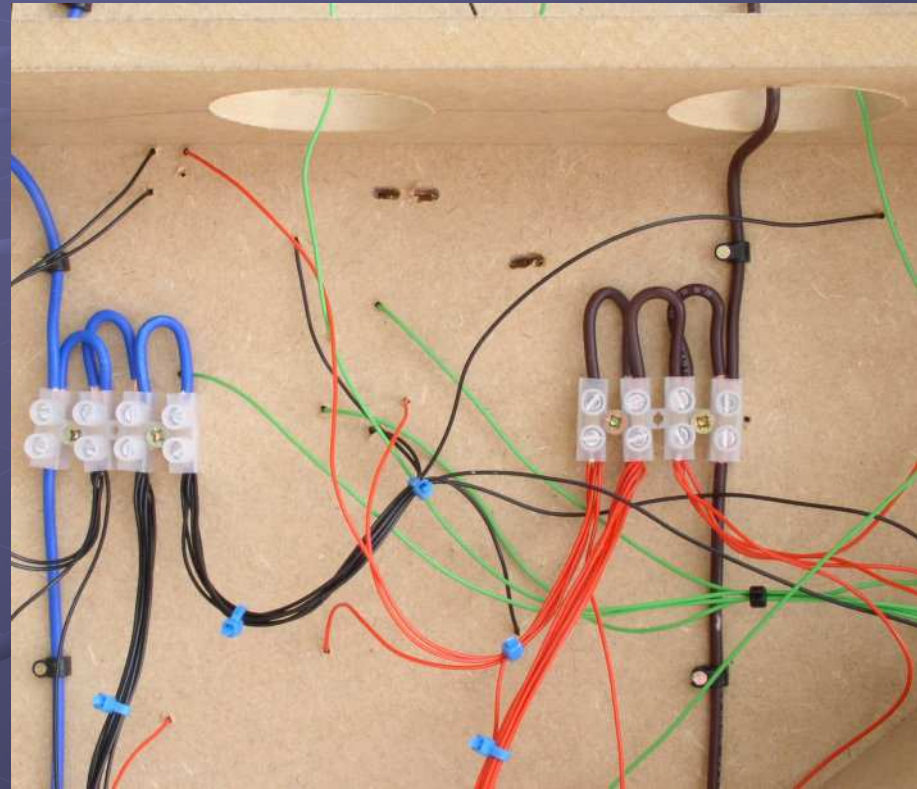

Photo of “Fence Houses” Layout by Les Waters
(with permission)

Terminal Blocks ... Consider Pluggable

- 2.54mm pitch Molex/JYK
Headers need crimping - see
TB P01/01 (22-0985)
- Various screw types
(21-2704, 21-2640, 21-2496)



DIY Distribution Board

- For lots of wires, consider a “Distribution Board” made from Stripboard + Terminal Blocks, Molex connectors etc.

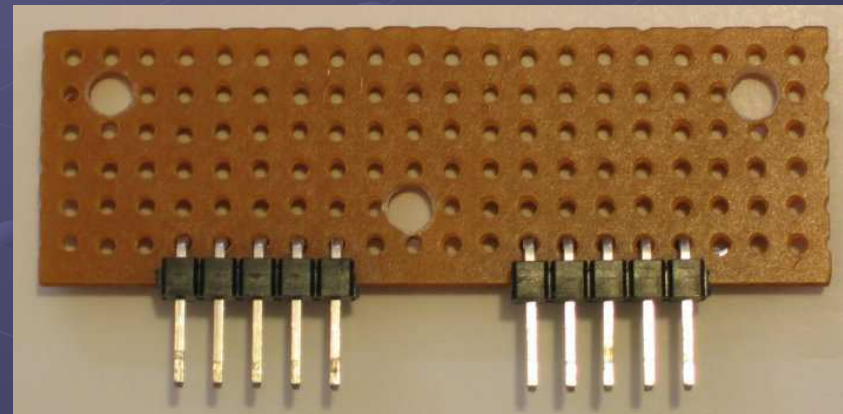
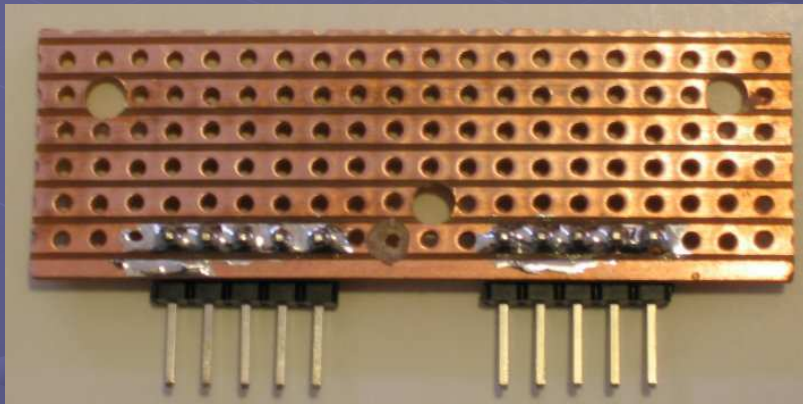

Wire & Cables

Multi-stranded vs Single Core

- Single core fails totally if the 1 core fails! (could happen years down the line if any flux was not washed off properly).
- Multi-stranded is more flexible, so more forgiving. Multi-stranded must be used where the cable can flex e.g. jumper cables.
- Single stranded OK on droppers (no movement) & Bus Bars.

Wire Sizes

- 7/0.2 = 7 strands of 0.2mm diameter
- Available in (resistor) colours & bi-colours
- Also 16/0.2, 24/0.2 & 32/0.2 available
- Each strand has a CSA (Cross Sectional Area) of .031 mm sq. So total CSA of 7/0.2 is $7 * 0.031 = 0.22$ mm sq
- Total CSA determines resistance & hence Voltage drop for a given current.

Wire Sizes – a Case Study

- Consider supplying a Solenoid Point Motor with 15V, 8 metres away.
 - 7/0.2 has a Voltage drop of 0.44 Volts/metre at 5 Amps.
 - 8 metres there & back = 16 metres
 - So total Voltage drop = $16 * 0.44 = 7$ Volts drop from 15V.
- => hence need for thicker wire

Sizes of Wire

Data Wires

7/0.2 (e.g. 01-0400)

- perfectly adequate for Data wires.
- rated 1kV rms 1.4 Amps @ 70° C.
- fits the Molex crimp connectors well.
- It is possible to fit 2 cables in one crimp, but barely possible to fit 3 (so make a “Distribution Board”).

Sizes of Wire

Power Wires

16/0.2 (e.g. 01-0900)

- rated 1kV 3A @ 70° C.

Suitable for

- Power supplies
- Solenoid Point motor power (use beefier wire if wire length >1 metre)

Sizes of Wire

Dropper wires

- Do NOT rely on fishplates – they **DO** deteriorate over time.
- use the largest wire you can efficiently and reliably solder tidily to the rails.
- Each piece of track needs (at least) 1 pair of droppers.
- Test each piece of track as it is laid.
- Do **NOT** solder to live DCC Track.
- Remember – PVA conducts when wet, need to wait several days before it is OK.

Sizes of Wire

Dropper wires

- Solder under the rail, or at the side if it can be hidden (some even poke the wire through a hole drilled in the rail).
- Droppers can be fine wire (solid or stranded), but should be kept short, especially on DCC.
- For N Gauge 7/0.2 wire is OK, other gauges use 16/0.2 or even 32/0.2.
- Connect to a **Bus Bar** (e.g. mains 2.5 mm² or lighting cable 1.5 mm², stripped from outer sheath)

What is a “Bus Bar”

- “an electrical conductor that makes a common connection between several circuits”
- Probably derived from “Omnibus” – common carrier.
- N.B. Both have conductors



What is a “Bus Bar”

- With a “Bus”, lots of point-to-point cabling is removed, just connect things to the bus rather than connect everything from the device all the way back to the panel.
- You could have several buses on a layout e.g. DCC (traction) & CBUS (accessories).
- JMRI can talk to several systems at once.

Sizes of Wire

DCC Bus

Use heavy gauge wire e.g. wire stripped from 2.5mm sq. household Twin & Earth.

- Ensures minimum loop resistance, so the fast acting trip functions on the DCC Booster, and better for double heading, lighting, sound etc.

Solder/Crimp droppers & connectors directly to these bus wires.

Wiring for DCC

(MERG Journal Summer 2007 p30)

- Phono plugs used for baseboard connectors

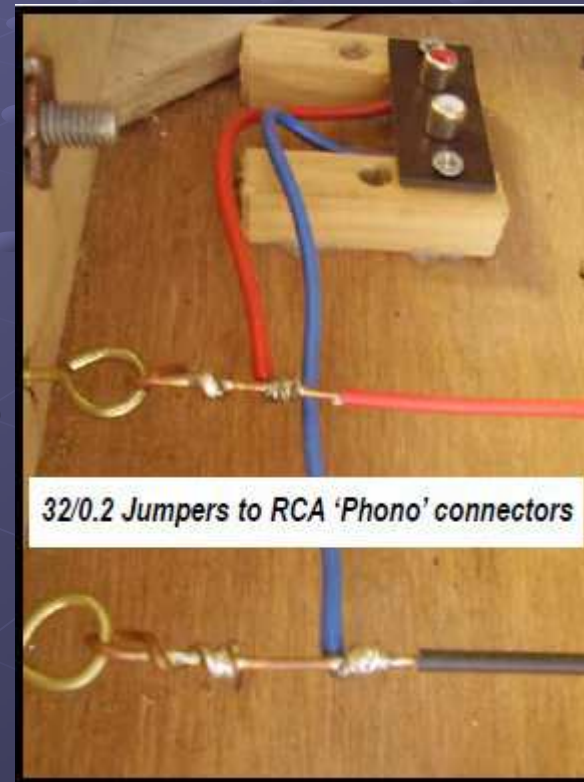

Wiring for DCC

- Use tag strips (Maplin FM34M), bend or cut ends to make a “V”.
- Wire droppers to base, and DCC Bus to the “V”s.
- Could use central position for frogs.

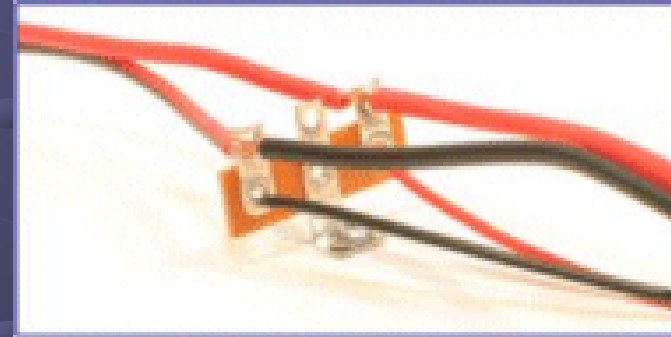
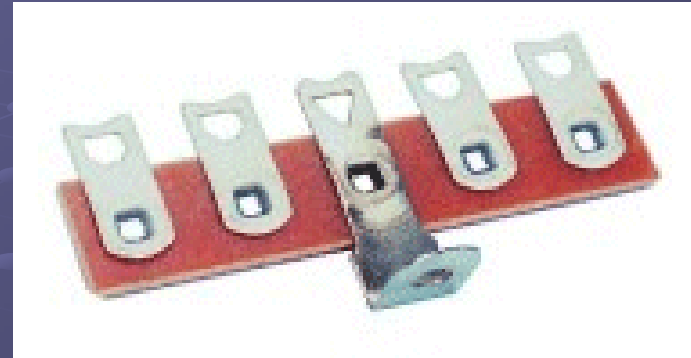

Wiring Points

- The Turnout Wiring Guide is reproduced by permission of Andy Reichert

<http://www.proto87.com>

- Another useful site (with details of slips, 3way points etc.) is

http://www.stciers.me.uk/home/track_wiring/pointwiring.htm

Wiring Points - Electrofrog

- Power Routing – self isolating sidings
- could stop siding at Y
- Relies on switch rails contacting stock rails
- Continuous Pickup but can cause shorts at X if clearances tight and/or wheels wide.

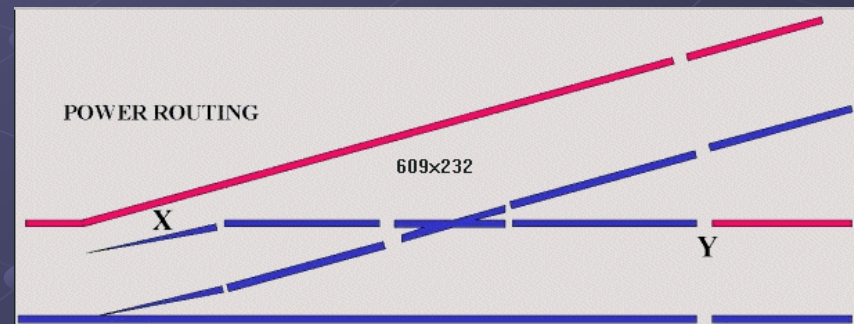
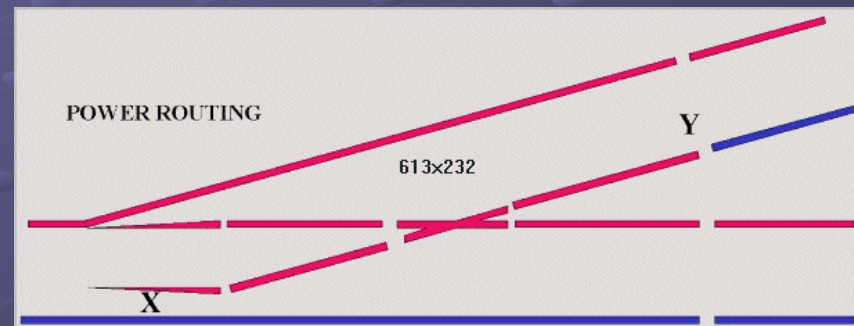

Wiring Points - Electrofrog

- Switching the Frog e.g. via a relay.
- Now have potential short. Relay may change before switch blades disconnect leading to a short (CANSERVO solves this with an event at mid travel).

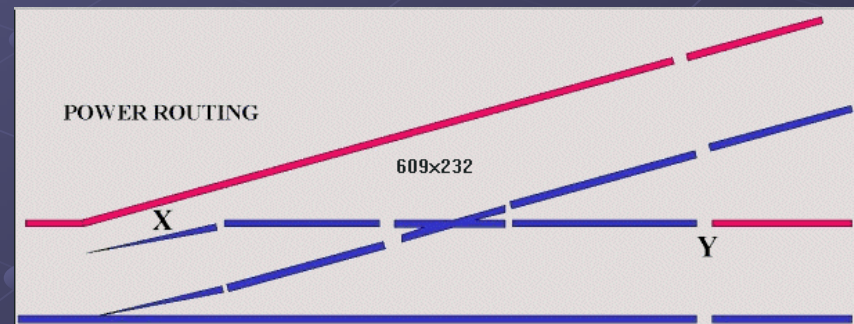
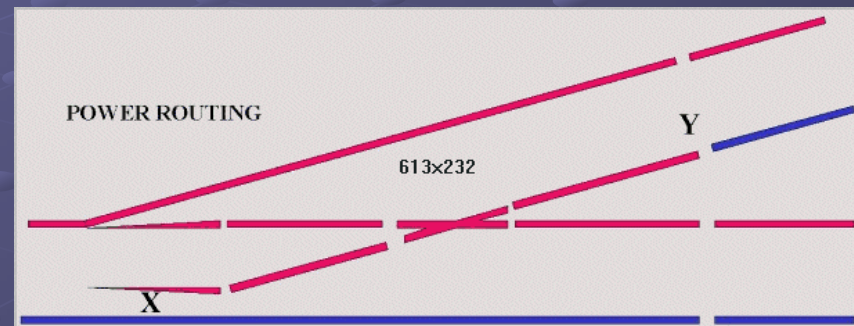

Wiring Points – Dead Frog

- switch rails bonded to stock rails “DCC friendly”
- No shorts between switch rail & stock rail
- Siding not isolated
- But - short wheelbase locos may stall on the frog

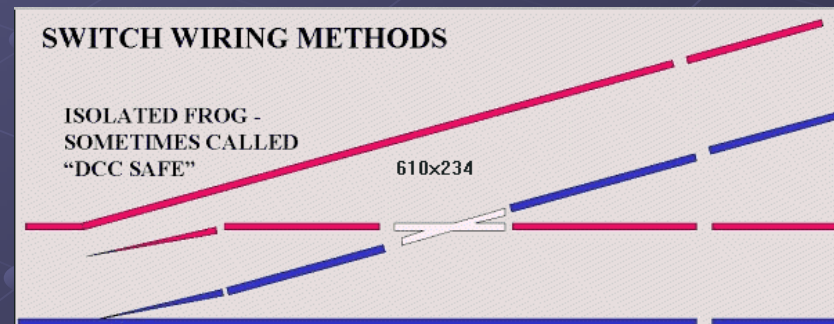
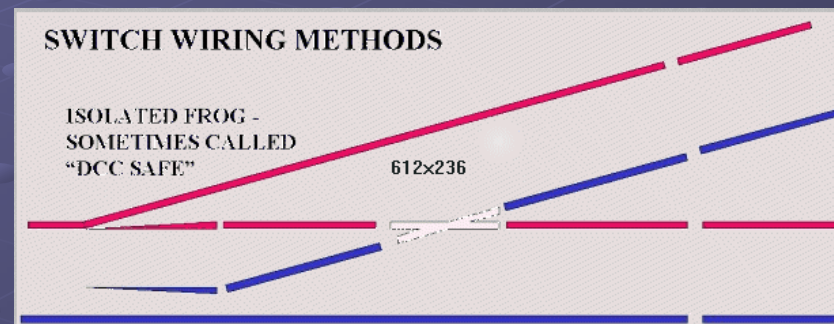

Wiring Points – switching the frog

- As before, but now with continuous pickup.
- Can get a short at Y if loco approaches with point against it

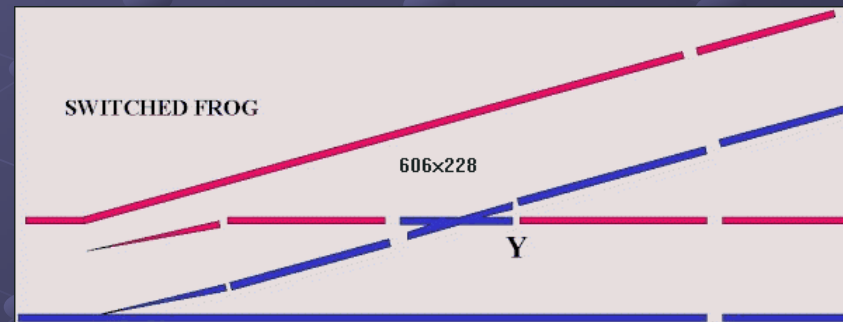
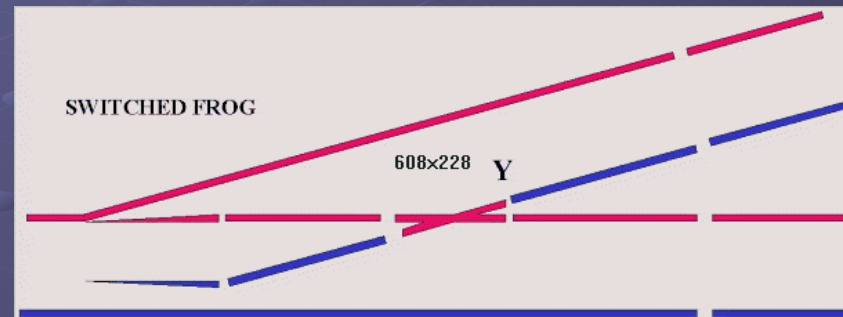

Wiring Points – add a Dead Zone

- Make the Dead Zone at least as long as the longest loco.
- Now a loco approaching the point set against its travel will stop before creating a short.

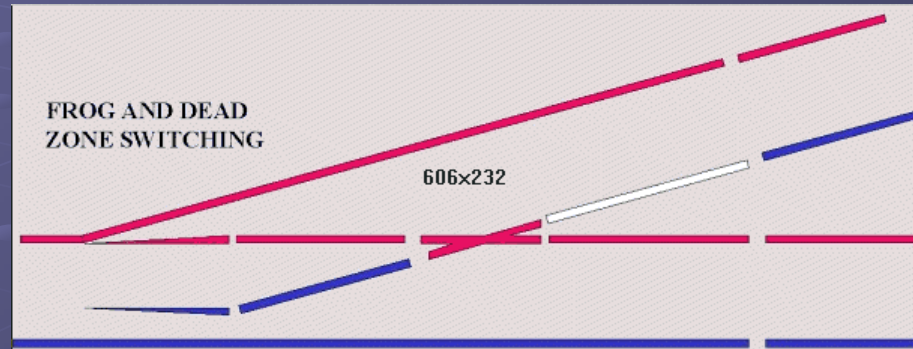

Wiring a Point (MISD6)

Use a relay to switch the frog & dead section

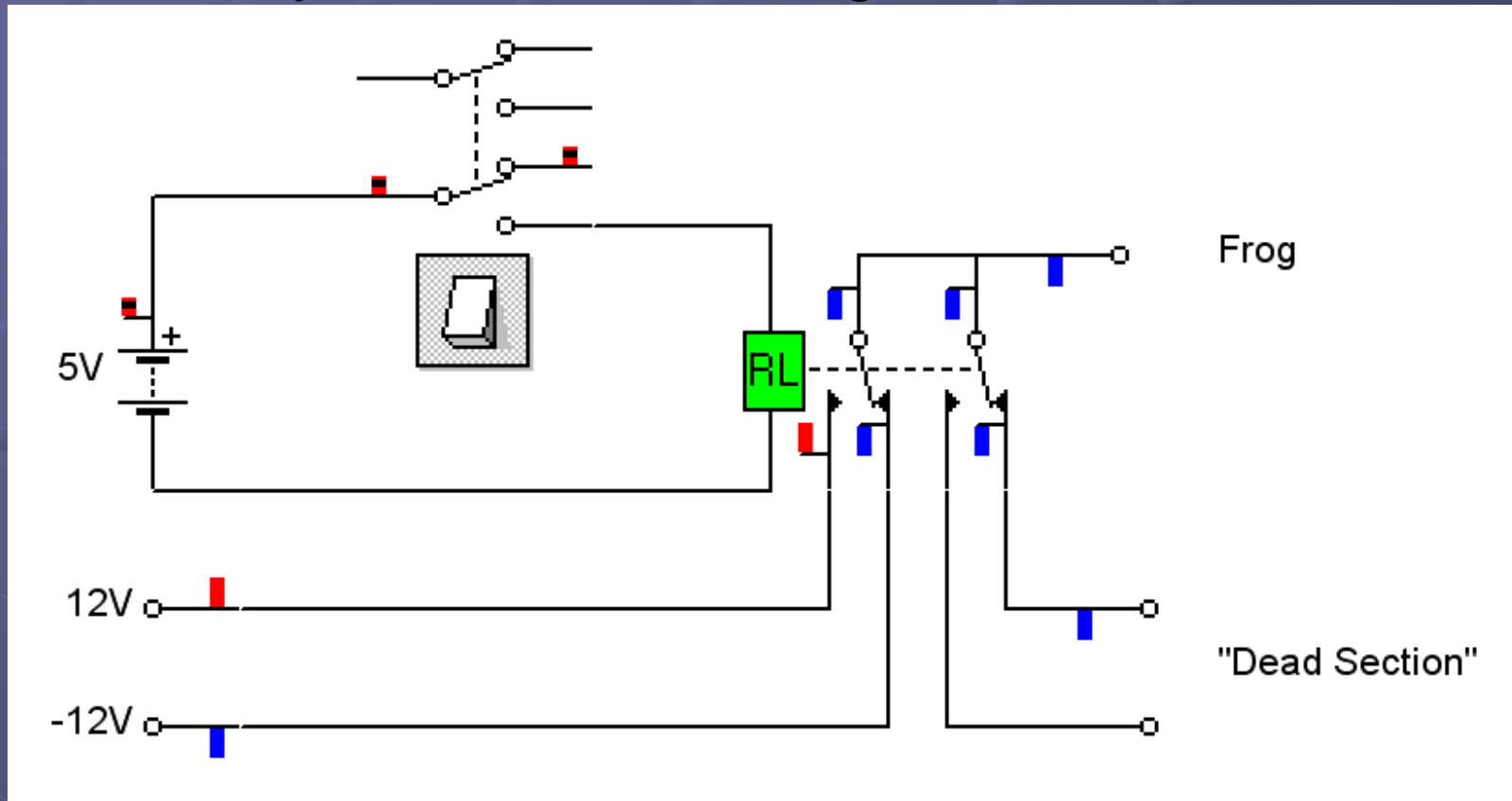

Wiring a Point (MISD7)

- Add Point Motor Control
- In Practice use appropriate Point Motor Drivers & Relay boards.

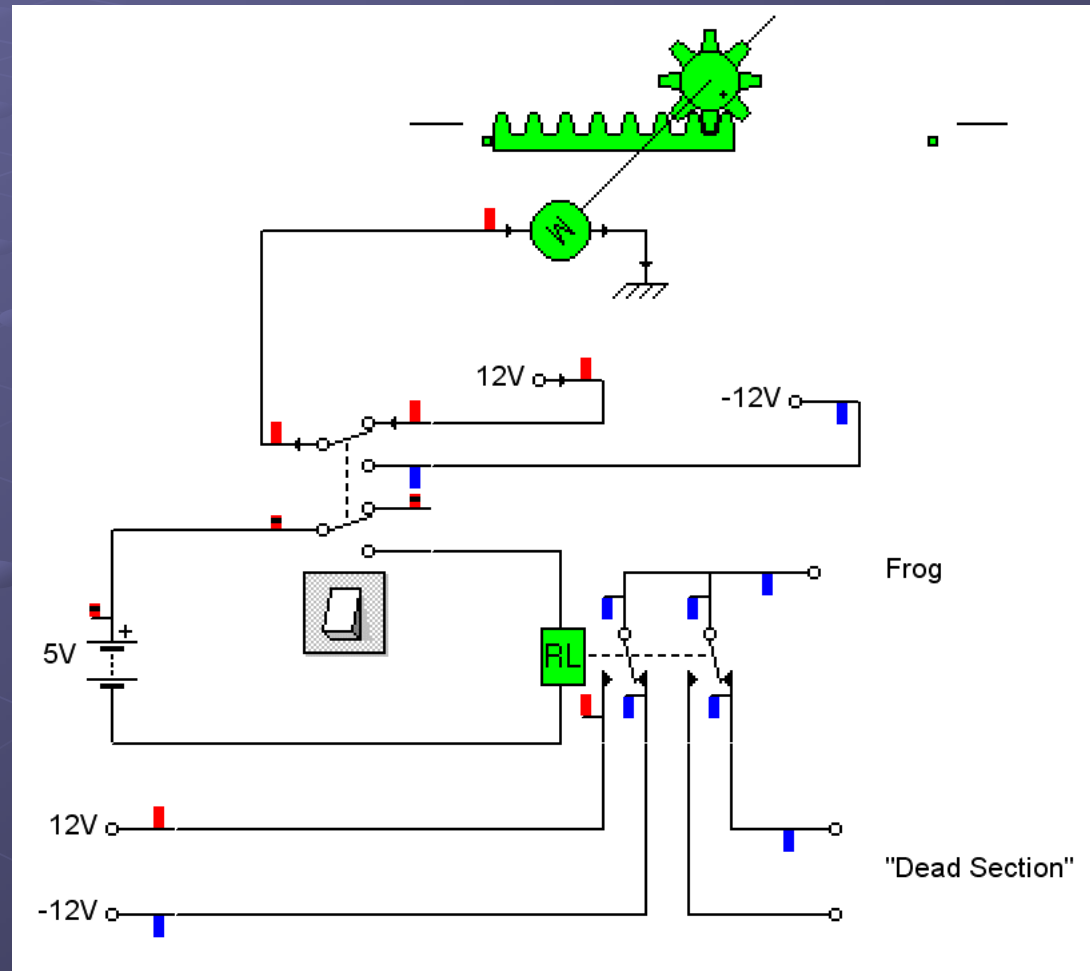

Think Ahead!

“I’m not looking forward to

- Wiring
- Ballasting”



What is DCC?

- DCC = **D**igital **C**ommand **C**ontrol.
- An NMRA standard.
- can control multiple trains on the same track(s) with the bare minimum of wiring.
- can control these trains independently of each other - different speeds and/or different directions on the same piece of track.

What is DCC?

Park anywhere, drive anywhere.

- Engine Shed, locos can park anywhere.
- Train arrives in terminus, loco uncouples, new loco arrives & couples to “back” of train. No need for section switches.
- Easy to make double headed trains. (“consists”)
- Banker, comes up to train, assists over gradient, then slows & returns **in opposite direction**.
- Slip coach can be motorised and stop precisely in platform.

How does DCC work?

- Full power is supplied to the track at all times, to all locomotives - helps get better pickup.
- The power is not DC, but includes Digital control signals - these provide instructions for individual locos.



- Power is alternating; non-polarised rails attract less dirt.
- Each loco has its own DCC decoder to receive these signals.

How does DCC work?

- Each Loco fitted Decoder can be customised for motor type, gear ratios, realistic top speed etc.
- Using decoders such as CT and Zimo gives “silly slow bottom speed which can be smoothly increased leading to better perception of scale mass for small scales”

How does DCC work?

- Decoders listen continuously for any signals addressed to their unique “address”
- When such signals are received, the decoders can act on the instructions.
- Instructions might be to stop, speed up, slow down, switch on lights, sound a horn etc.
- The decoders ignore any control signals not addressed to themselves and carry on doing whatever they were doing before.

How does DCC work? (MISD8)

- Decoders contain small, high power switches to control the motor speed and direction.
- locos move forward according to loco direction, not track direction.

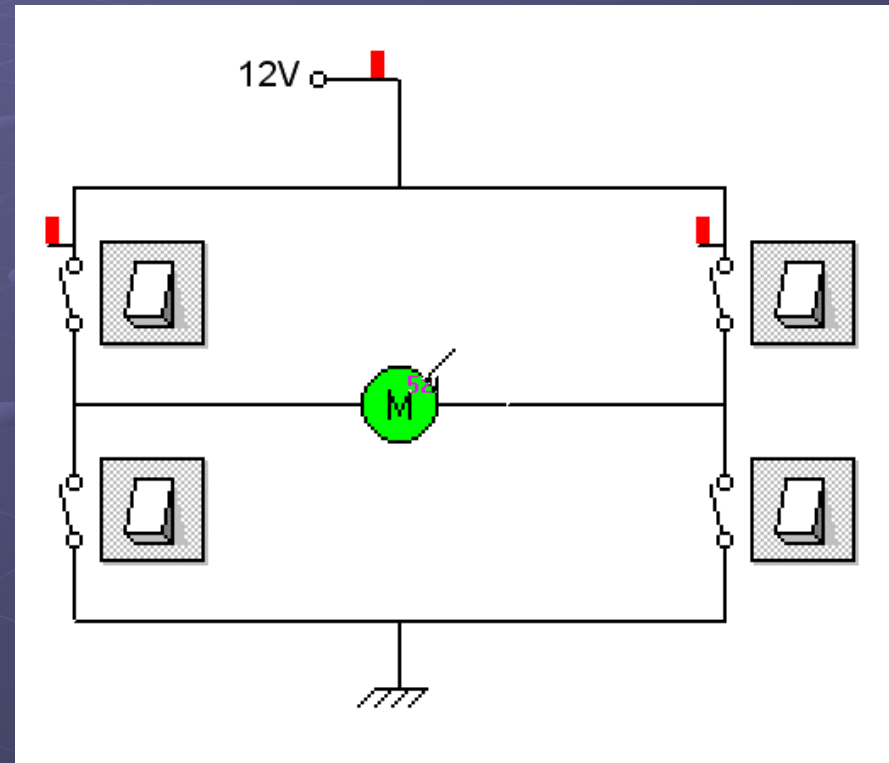

DCC hardware

- DCC controllers/throttles
- A command station (CS) to convert controller's button pushes to DCC signal.
- Booster to boost DCC signal to give it more power, perhaps combined with CS.
- DCC decoder in locos. Can be **ANY** make of NMRA decoder.

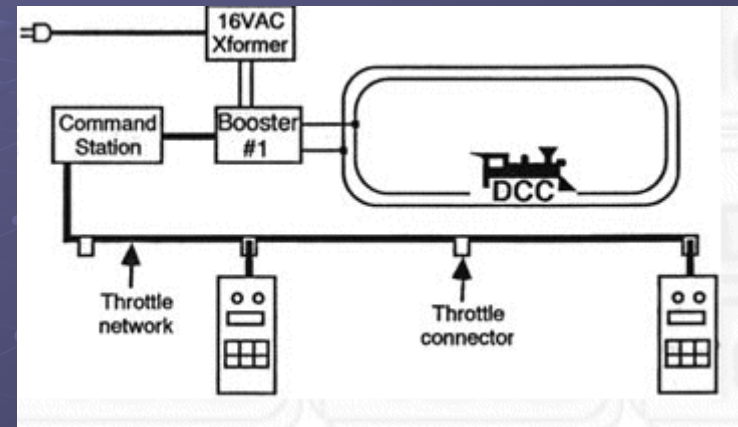

- Throttle network is proprietary,
 - Xpressnet (Lenz)
 - Loconet (Digitrax)
 - CBUS (MERC)

How to wire for DCC

- **MUST** isolate motor from track pickups
- Decoder wires are colour coded
 - **Red & Black** go to the **Track**. Red on the **Right**
 - **Orange & Grey** go the **other way** (to the motor)
 - Blue is common (+) for functions
 - other colours are for individual functions e.g. white (front lights), yellow (rear lights) etc.
 - Can have 2, 4, 6 function decoders.

Suggestion for moving to DCC

- You *can* run **one** non-DCC locomotive on a DCC system. But the motor vibrates, is noisy & is probably not doing it any good. **Not recommended.**
- However a DCC “chipped” locomotive can still run on a conventional layout. Therefore you can convert them a few at a time.
- An existing layout can have some sections on DC some on DCC, just be careful over section breaks.

Programming DCC

- Not really “programming”, but setting values to CVs (configuration variables).
- Essential Programming – setting loco address. Does need a separate “programming track”
- Useful programming – setting top speed, inertia.
- Advanced programming – anything else!
Function buttons, speed curves, fine tuning BEMF etc. Easier with a computer & DecoderPro (free download from JMRI)

Controlling Points

- **NOT** essential to control points with DCC even if all locomotives are DCC.
- You can control points with whatever method you prefer and are used to.
- conventional point control isolates sidings if the point is set the other way. You can still do this with DCC, but are then losing some control possibilities (lights, sound).

DCC Layout Summary

Across baseboards you need

- 2 wires (*) for track – use Bus Bars
- Throttle network (Xpressnet, Loconet, MERG CBUS etc.)
- Power supplies
- (*) Big layouts may use several power districts e.g. Up line, Down line, Fiddle Yard.



MERG Kits

Introduction to MERG kits

most MERG kits use

“Open Collector” or “Active Low”.

- When the output is active, it is connected to ground (so current can flow)
- When not active = open circuit, no current flow.
- This makes it easier to join multiple kits together.
- allows for 1 output OR the other to be effective.
- For further details see

http://en.wikipedia.org/wiki/Open_collector

Active Low (MISD9)

- Can be used as “Wired OR”
- Can connect devices with different positive Voltages...

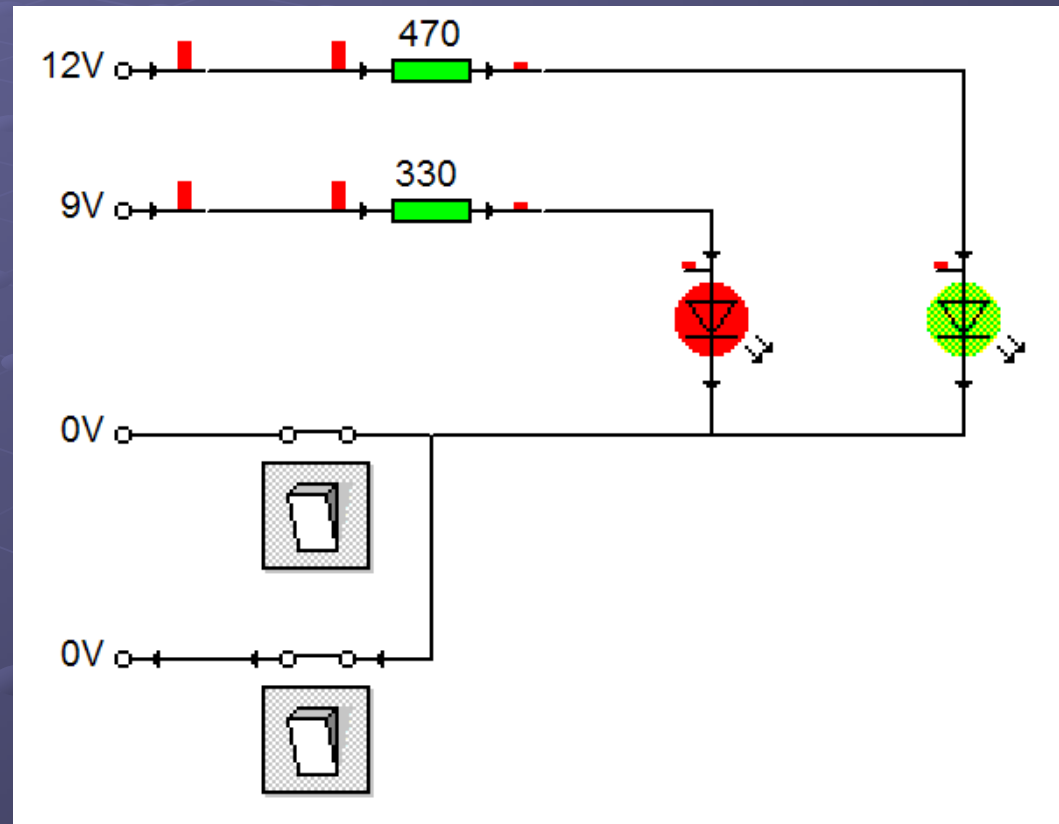

Active Low

- Control 12V relays from 5V CBUS device.

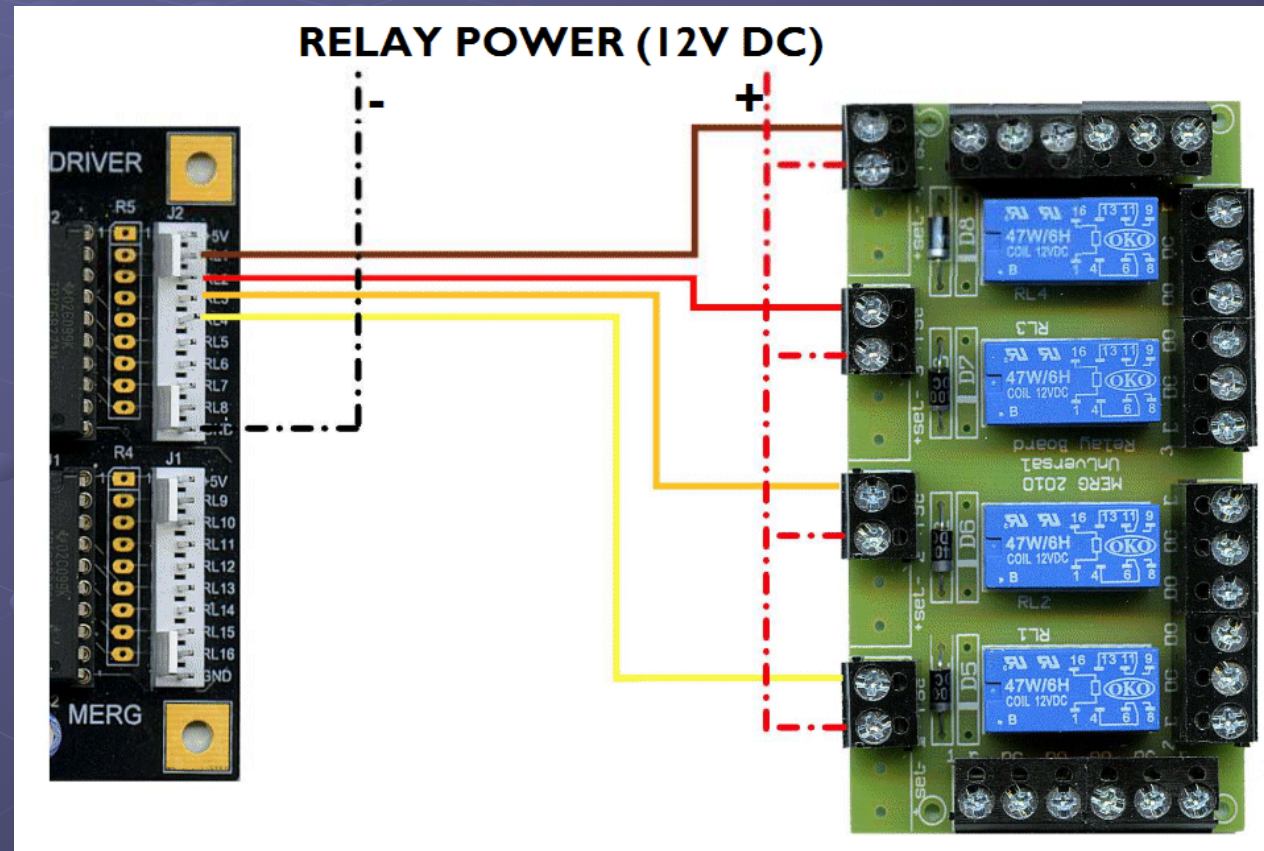

Introduction to MERG kits

For the range of Kits see the Public page

<http://www.merg.org.uk/kits.php>

Or the Member's page (more information)

<http://merg.org.uk/forum/stores/shops.php>

Choosing a MERG Kit

What do you want to do?

- Stand alone kits vs. systems
- DCC vs Analog
- Mixing with existing systems
- Layout Control - Control panels, Point motor feedback, LEDs etc.
- Train Detection

MERG Kits

There are individual kits

- Gas Lamp Twinkler
 - Relay boards (Mark 1 is active high)
 - Signal drivers
 - Point Motor Drivers
 - RFID
 - TOTIs (Train On Track Indicators)
- etc.

MERG Kits

There are Systems of kits for Layout Control

- RPC
 - DCC
 - CBUS
 - PTP-Lite
 - SuperBloc or BC3
 - ATC & CSR
- etc.

RPC (Remote Panel Control)

- A system of plug-in modules for remote control of points, signals, sections etc.
- Can be interfaced to a PC, or Point-to-Point (PTP) manual control between control panel & layout.

http://www.merg.org.uk/merg_resources/rpc.php

- PC control can be via TCC from ex-MERG member Howard Amos.

<http://www.qtutrains.com/>

MERG DCC Kits

Accessories (better to use CBUS)

- kit 51: Mimic Panel Encoder
- Kit 52: Accessory Decoder (Solenoid)
- Kit 53: Accessory Decoder (Motorised)
- Kit 54: PC interface to Encoder (Optional)

N.B.

- Kits 52 & 53 can be used with any NMRA DCC system.
- Kit 51 is essentially a DCC command station fed by switches. Can be used on Analog Layouts, or provide separate DCC point control

MERG DCC Kits Traction

- Complete extensible system - 5Amp, NMRA compatible
- Uses CBUS between Command Station & Handset (**surface mount**), so no extra wiring if already using CBUS. Can add CANUSB for computer interface
- Interfaces with JMRI & RocRail



CBUS

- Bi-directional Layout Control System using 2 wires (+ 2 for power)
- For either DCC or analog
- Based on CAN (Controller Area Network) bus as used in “noisy electrical environments” such as motor vehicles, aircraft, medical scanners etc.
- Includes feedback, point motor drivers, switch input etc. etc.
- Teaching via switches or PC program.

CBUS

- 2 types of modules, Producers (generate events from switches etc.) & Consumers (use events to drive LEDs, Relays etc.).
- Can be used in **SLiM** or **FLiM** mode
- **SLiM** (Small Layout Model) does not require a PC. Consumers can be taught to respond via switches.
- **FLiM** (Full Layout Model) gives more control, but requires a PC for setup.

PTP-Lite

- A simple stand-alone layout control and feedback system.
- Two types of modules Peekers (8 input) & Pokers (8 output).
- One Peeker can only talk to the one Poker with the same address (not as flexible as CBUS).
- For point control, have to interface to stand-alone modules e.g. Servo4 (unlike CBUS)

Superbloc or BC3

- Automatic block control for analog systems (i.e. NOT DCC)
- Each “section” has its own BC3 controller
- Automatically stops trains if the block ahead is occupied.
- Large number of TBs available T33/01 to T33/23

Automatic Train Controller (ATC) Analog Only

Figure 1 - Shuttle Configuration A (Simple)

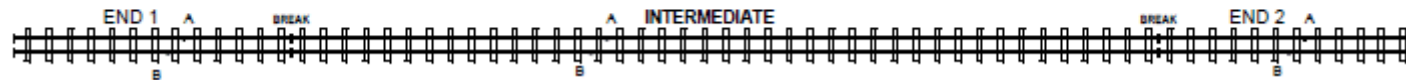

- ATC allows several shuttle modes.
- Can be expanded with CSRs (Cab Select Relay)

Figure 3 Shuttle Configuration B

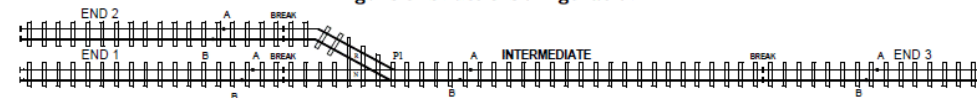

Figure 4 Shuttle Configuration C

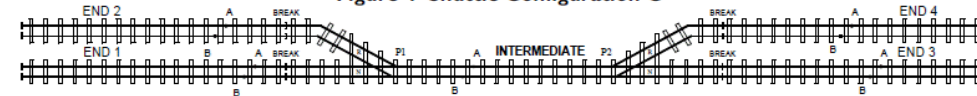

Figure 5 Shuttle Configuration D

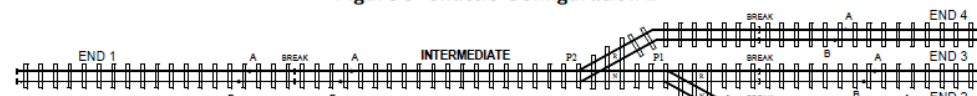
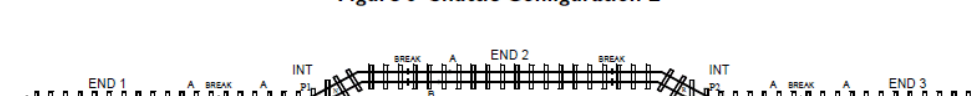

Figure 6 Shuttle Configuration E



Train On Track Indicators (TOTIs) (position or Block Indicators)

● DCC Only

- DCC TOTI, diode drop via Schottky diodes. Available as 8 channel SM PCB (kit 968) & 1 channel through hole Veroboard PMP7. Negligible Voltage Drop
- Current Transformer DTC8 kit 56, no Voltage drop.

● DCC or Analog

- TOTI4, TOTI12 kits 62, 63 works by diode drop
- Infra Red e.g. MERG "Hector" kit 72, tells you where something is.
- RFID tells you WHAT something is.



How to Drive Point Motors

How to Drive Point Motors

- (Mechanical e.g. wire-in-tube)
 - Solenoid (Clunk Click every trip)
 - Motorised (Fulgurex, Lemarco, Tortoise)
 - Servo Motors.
-
- Individual Drivers
 - DCC (even for Analog Layouts)
 - CBUS

Individual Point Motor Drivers

- Kit 37a/b Dual Capacitor Assisted
- Solenoid Point Motors
- Needs 1 wire from Control Panel/point



Individual Point Motor Drivers

Gordon Hopkins's PMD1 or PMR1 with relay

- A self-contained Capacitor Discharge twin-solenoid motor driver, controlled by a single low current wire.



DCC System for Point Motors

- Does not have to be used with DCC traction (best to keep traction and point control separate anyway)
- Different types of Point Motor drivers for Solenoid & for Motorised Points
- Controlled from switches on a Control Panel (with the OPTION of Computer Control)

DCC System for Point Motors

- Kit 52: DCC Solenoid Point Motor Driver
- 4 points
- On board Capacitor Discharge.



DCC System for Point Motors

- Kit 53: Motorised Point Motor Driver
- 4 points

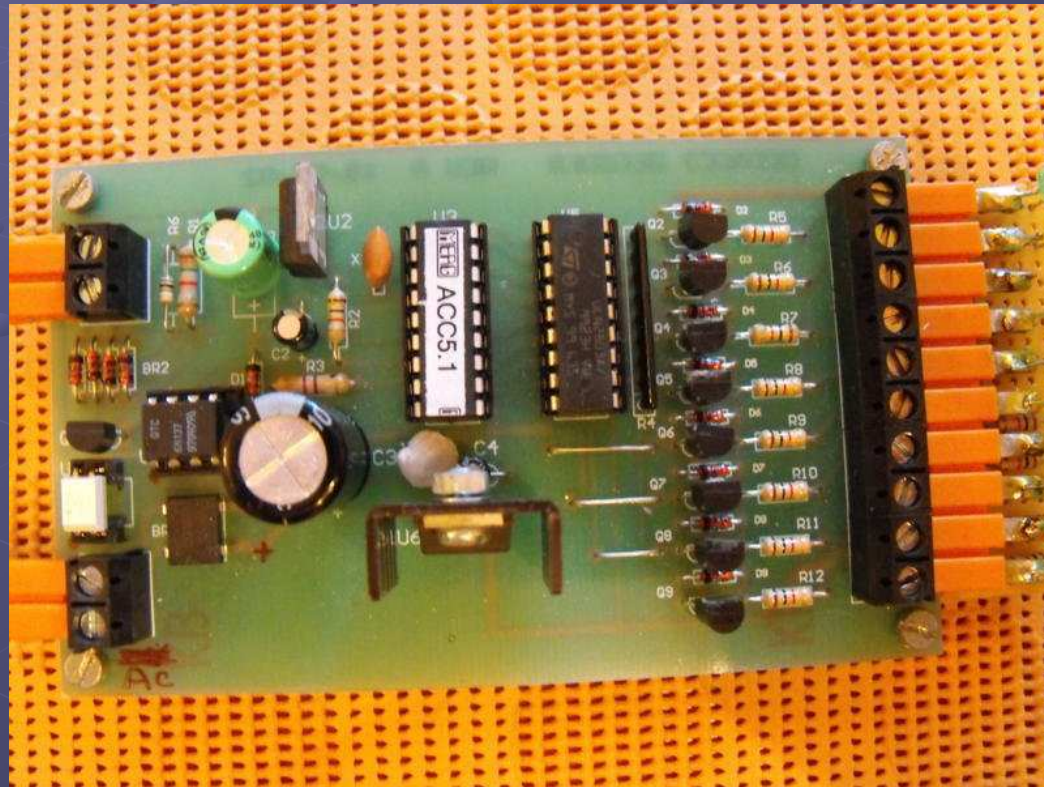

(picture by David Sims)

DCC System for Point Motors

- Kit 51: Mimic Panel Accessory Encoder
- Up to 128 Switches

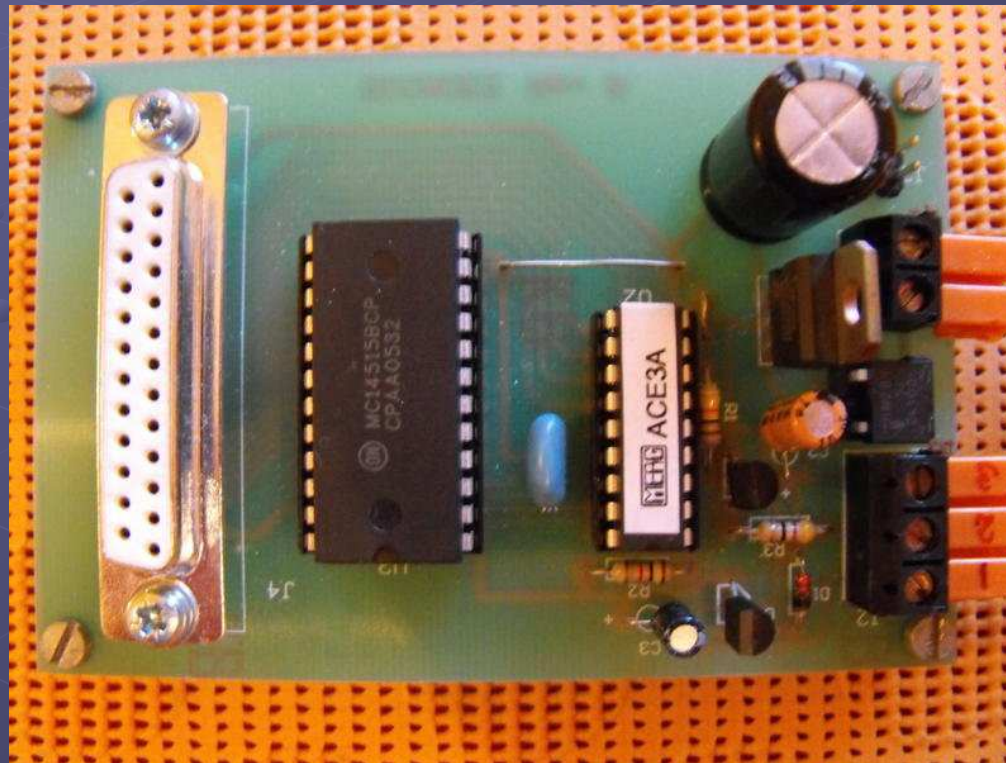

(picture by David Sims)

Servo Point Motor Driver

- Kit 75 can drive 1-4 servos.
- Each can have separate control of end stops.
- Stop 1 can be clockwise OR counter-clockwise.
- Each can have different speeds (forwards & back)
- Setting is via a PC, or Kit 76, can be done **ABOVE** the baseboard.



Servo Mount kits 681 (3D printed)

- Point Motors (kit 681)
- Semaphore mounts - single (684), double (685), quadruple(686)
- Gates (690)
- Colour Light Signals (689)
- Microswitches (683)

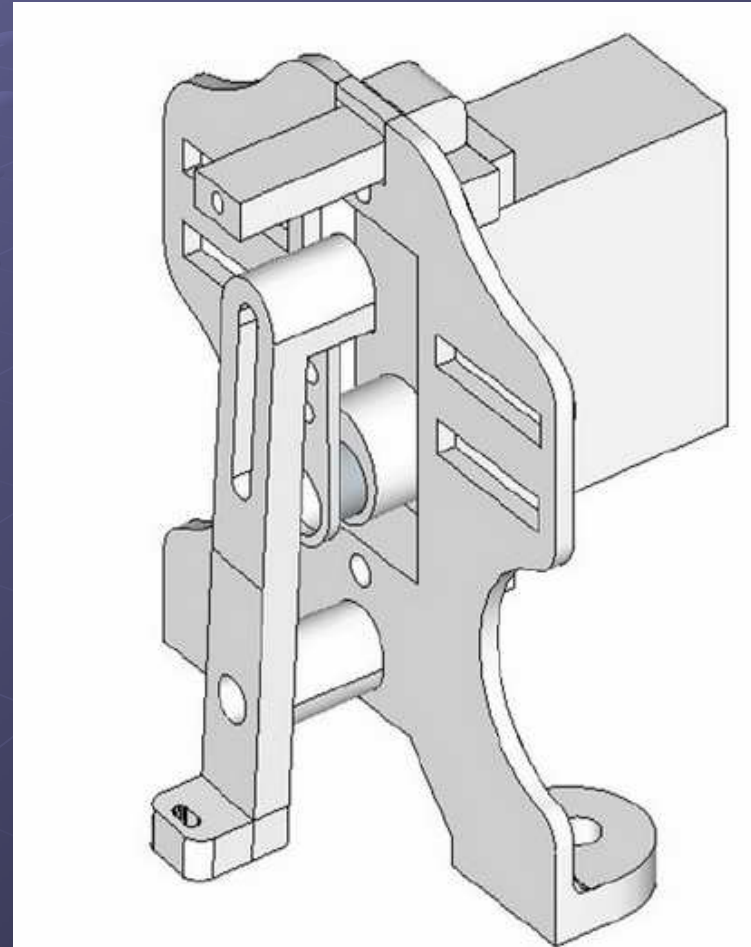

Setting Servo Motors

- Settings can be saved to/from a file

The screenshot shows the 'MERG Servo 4 Setup Version 3.02 Trevor Stockill M2433' application window. The interface is divided into several sections:

- Hardware Diagram:** A green PCB layout on the left with a red arrow pointing to it.
- Servo Select:** A panel with four radio buttons labeled 'Servo 1', 'Servo 2', 'Servo 3', and 'Servo 4'. Below it is a checked checkbox for 'AUTO POSITION'.
- Speed Controls:** Two columns of controls. The left column is labeled 'SPEED ON' and the right 'SPEED OFF'. Each has a digital display showing '04' and '127', a 'MAX' label, a vertical slider, and a 'MIN' label. Below each column are 'TEST' buttons and 'Click To Set' text.
- Servo Position:** A large orange gauge on the right labeled 'SERVO POSITION' with a needle pointing to 0. The scale ranges from -127 to 127 with intermediate markings at -85, -42, 42, and 85. A 'QUADRANT' button is at the bottom right.
- File Management:** At the bottom left, there are input fields for 'Current File' and 'Last Command', and three buttons: 'Load From File', 'Save To File', and 'Save All To Board'.
- Close Button:** A 'CLOSE' button with a window icon is at the bottom right.

Switching the frog

(changing the polarity of the crossing Vee)

Can be

- Done separately
- Via built in switches on point motor (driver)
- Via add-on (micro)switches
- Automatic for DCC (“Hex Frog Juicer”)

Switching the frog Separately

- extra electronics, e.g. double pole relay. One pole controls the PMD, one changes frog polarity.
- One danger is that polarity might change when the point blades are still in contact. With “non DCC friendly” this could lead to a short.
- No feedback is possible.

Switching the frog via built in switches – Fulgurex/Lemarco.

- 1st bank cuts power at end of travel
- 2nd bank can be used to switch frog
- 3rd bank (or 2nd bank on RHS) can be added for feedback
- Best to use crimp terminals, not solder to avoid damaging the plastic (how do I know?).

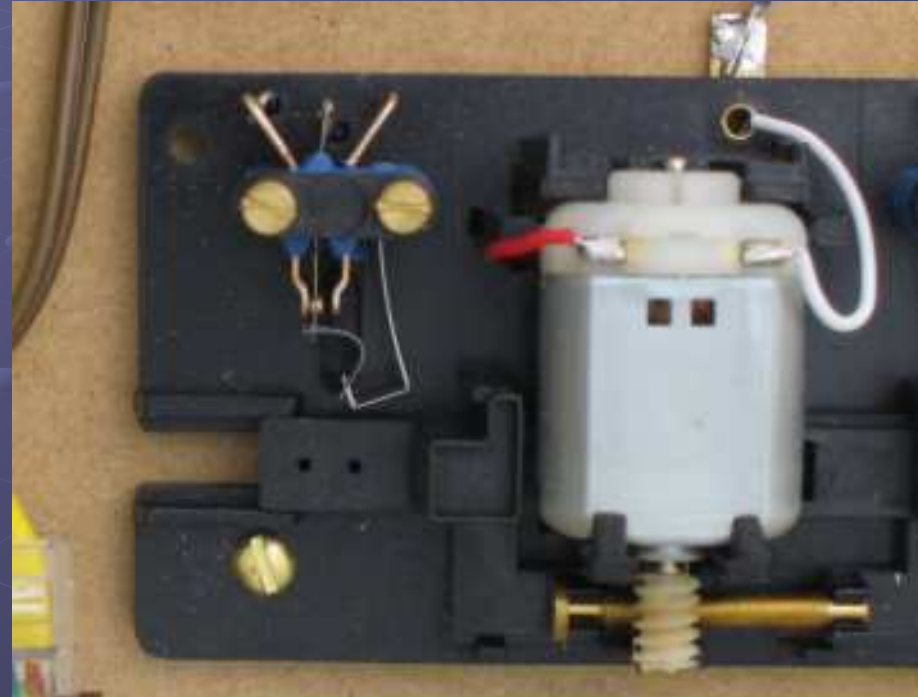

Switching the frog via built in switches – Tortoise

- Includes 2 sets DPDT switches.
- Work by wiping a contact on PCB – short term reliability? (same as Seep point motors).
- The internal changeover will occur before the point is fully thrown.



Switching the frog via add-on switches

- Example using Peco point motor.

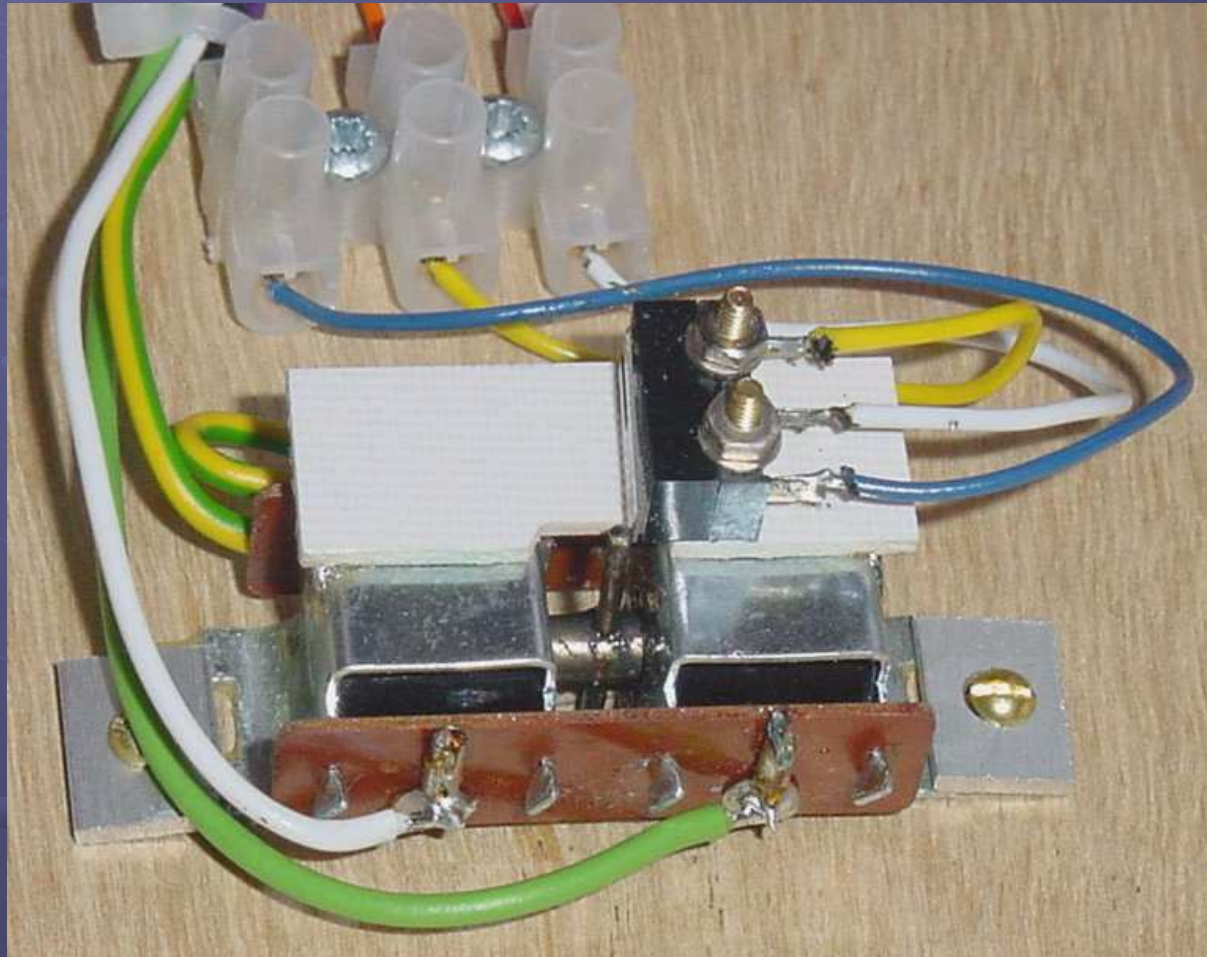

(photo by Mike Bolton)

Getting Feedback

Several methods

- DPDT switch – shows switch has changed
- Add on microswitch – shows PMD has changed
- extra wiring on frog – shows change took place.
- Still a problem if linkage to point blades is broken.

Using LEDs

Control Panels
In Rolling Stock
etc.

LEDs

Possibly the most useful electronic component.

- mainly 3mm & 5mm for kits & Control Panels
- Colours – red/green/yellow/blue/white
- Output – dim/bright/very bright (measured in mCd = milli Candelas)
- Bi-coloured (2 leads) e.g. red/green
- Tri-coloured (3 leads) e.g. red/green
- Tri-colour may be common anode or common cathode.

MUST have a current limiting resistor (unless built in e.g. 12V LEDs)

Fundamental Equation for LEDs

- Look up LED characteristics
 - V_f = Forward Voltage, typically 2 V
 - I_f , LED current, must be less than maximum allowed, typically about 20 mA
- Calculate limiting resistor from source Voltage V_s

$$R = (V_s - V_f) / I_f$$

- Or use <http://led.linear1.org/1led.wiz>
- Can vary R to adjust brightness

LED Tester (Rapid 55-0000)

~£5.40

Use this to

- Compare brightness
- Check LED works.
- Check orientation.
- Check colour!



LED Simulation (MISD10)

$$R = (V_s - V_f) / I_f$$

$$R = (12 - 2 \text{ Volts}) \text{ divide by } 10 \text{ mAmps}$$

$$R = (12 - 2) / 0.01 \\ = 1 \text{ kOhm}$$

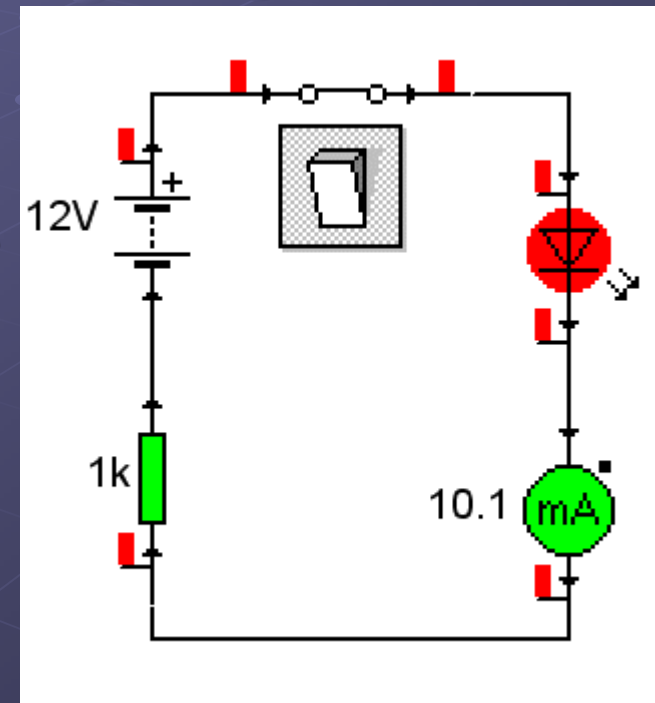

LED Simulation (MISD11)

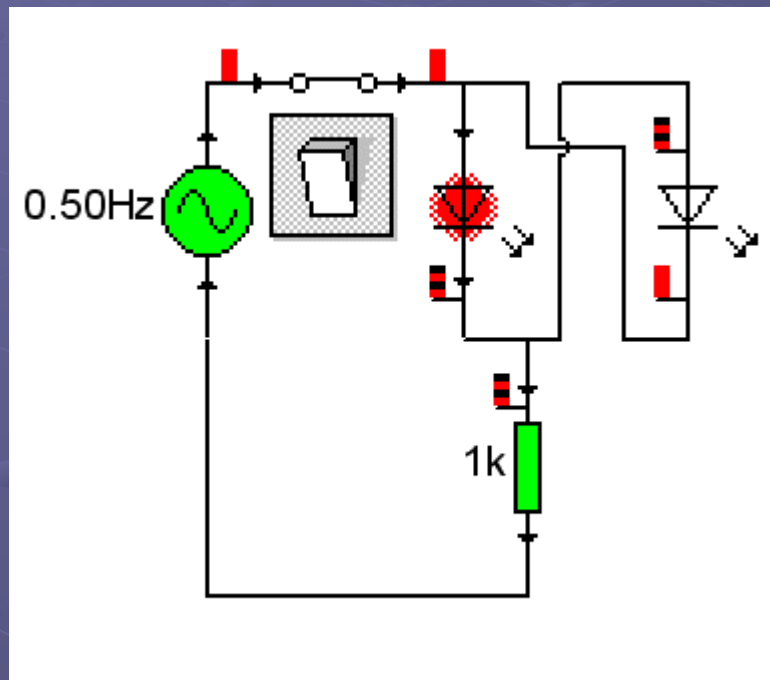

- Bi-coloured LED
- red/green - yellow
- 2 wires
- 2 LEDs in inverse parallel in one case
- Needs just one resistor

LED Simulation (MISD12)

Common Anode Tri-coloured LED

- Red or green or both (yellow?)
- 3 wires
- 2 LEDs in one case
- Needs 2 resistors
- Common Anode not available in 3mm (common cathode are).

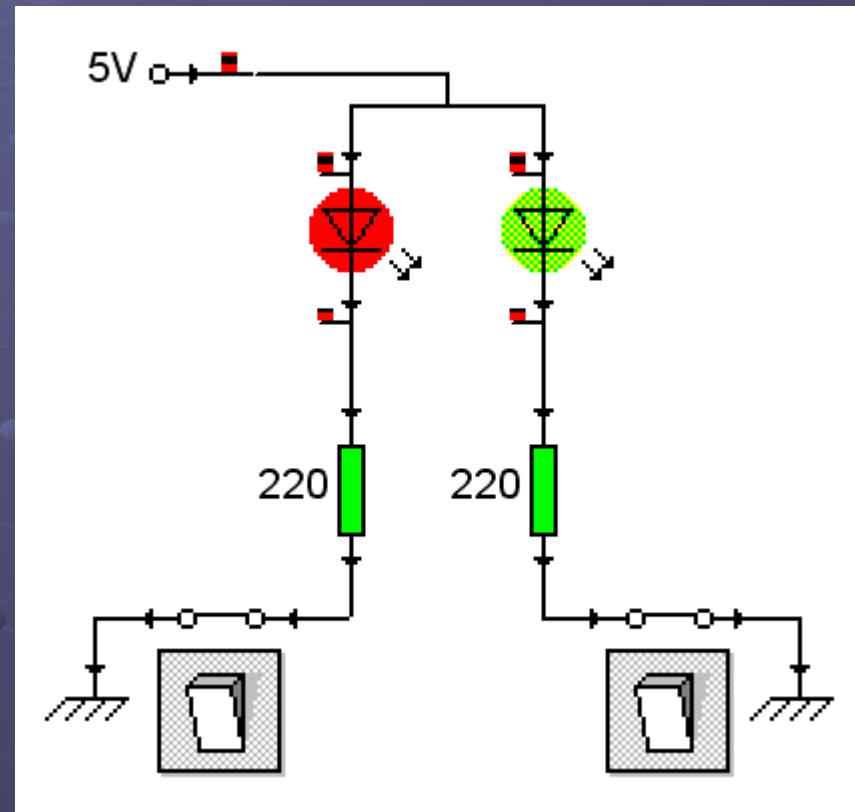

LED Simulation (MISD13)

- Common Cathode Tri-coloured LED

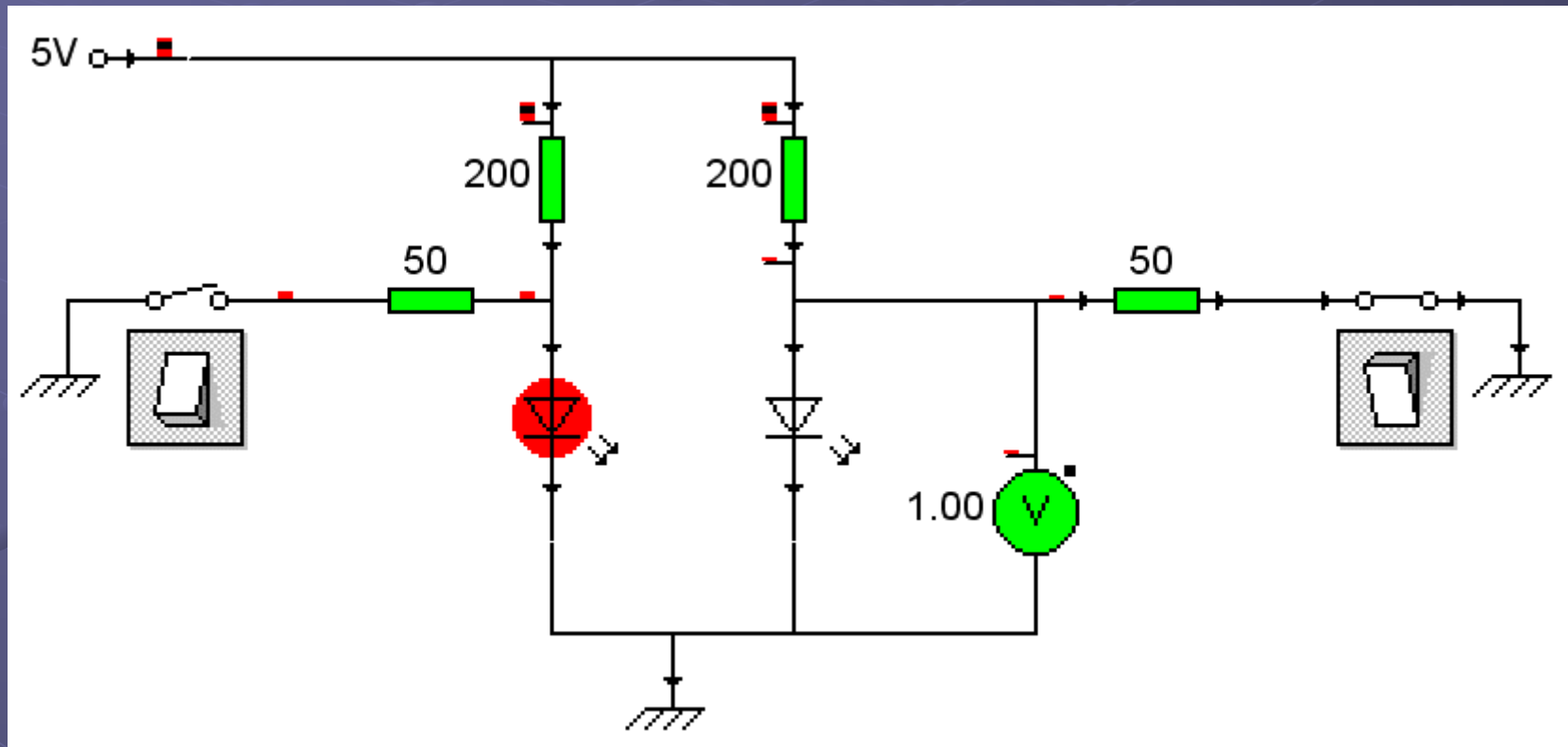

LED Fundamentals

- Maximum reverse Voltage for LEDs is typically 5V (cf 50V+ for diodes). Hence need for reverse diode in the relay simulation (MISD5).
- All LEDs **MUST** have a current limiting resistor. Do **NOT** apply directly to a battery
- If LEDs are in parallel, each **MUST** have its own resistor.

LEDs in series (MISD14)

Note
different
Voltages
(V_f)
across
each
LED

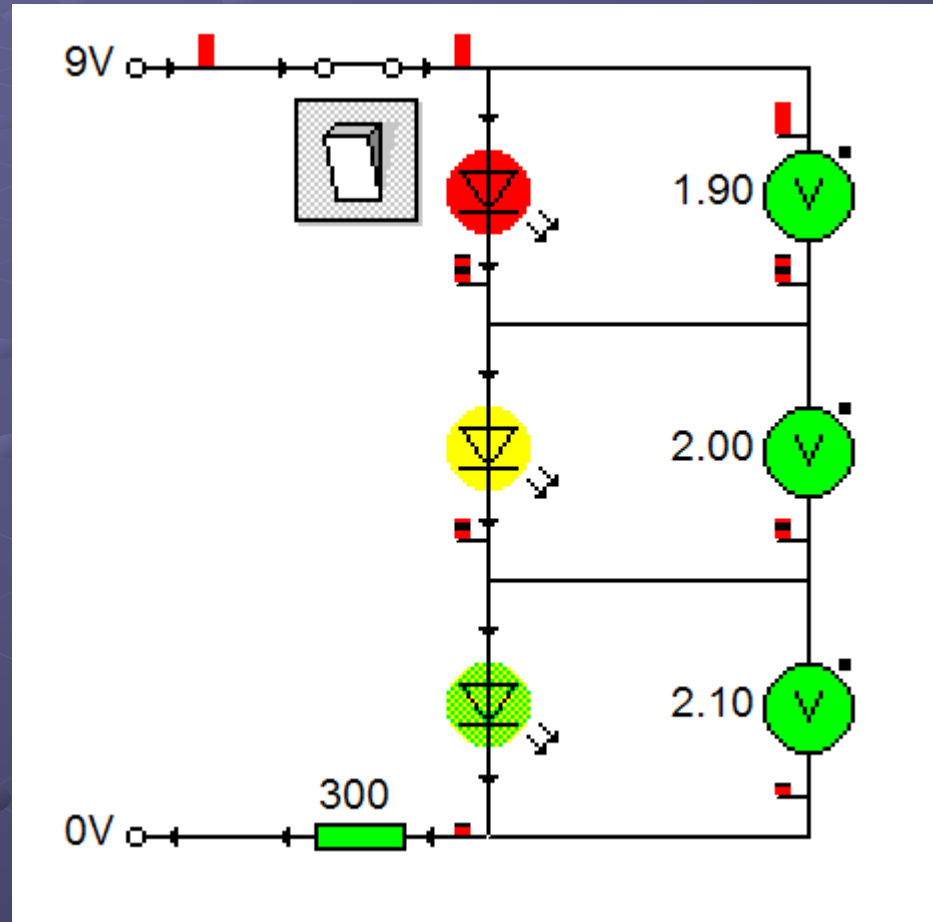

LEDs in Parallel (MISD15)

Red LED
drops
1.9V,
green
LED
needs
2.1V

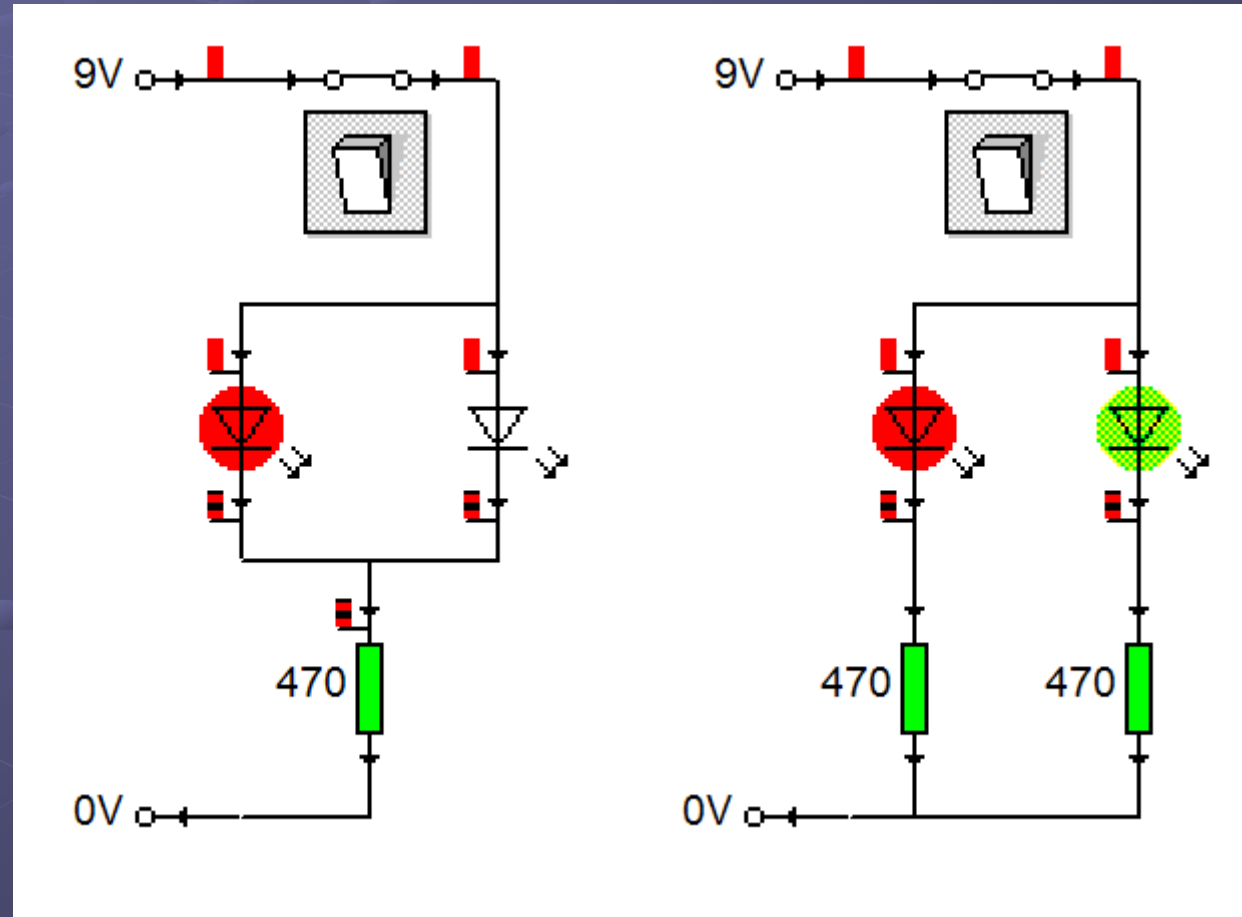

LED Simulation (MISD16)

Novel use of Common Anode

- Switch open
Green lights up
Why?
- Switch closed
Red lights up
Green goes out
Why?
- Hint: Voltage

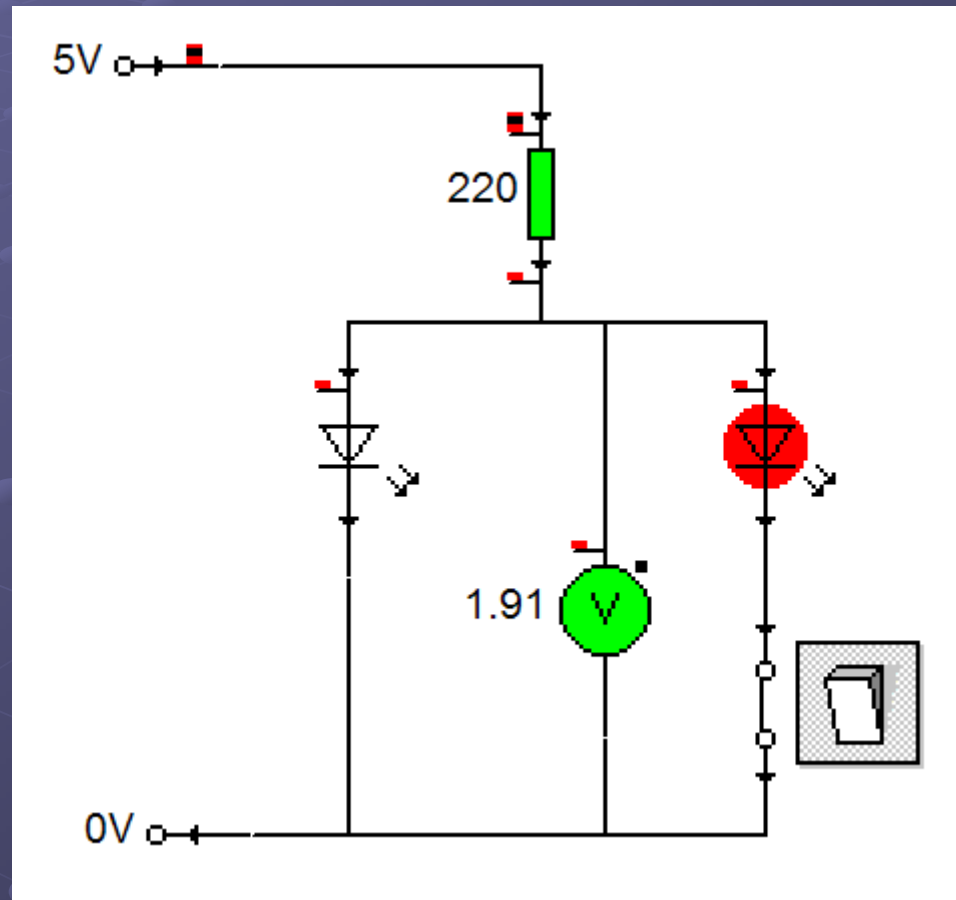

Flashing LEDs

An LED can be made to flash via

- An IC such as a 555 timer
- A program in a PIC
- Built into kits (e.g. CANLED64)

But Flashing LEDs are available that include a suitable IC. (3mm 56-0760, 5mm 55-0140)

- The frequency is typically 3 Hz and cannot be changed.
- They require no series resistor, but need 9-14V

Using a 555 timer to flash LEDs

One of the example circuits in CrocClips (555-OSC)

555 timers not covered in this course.

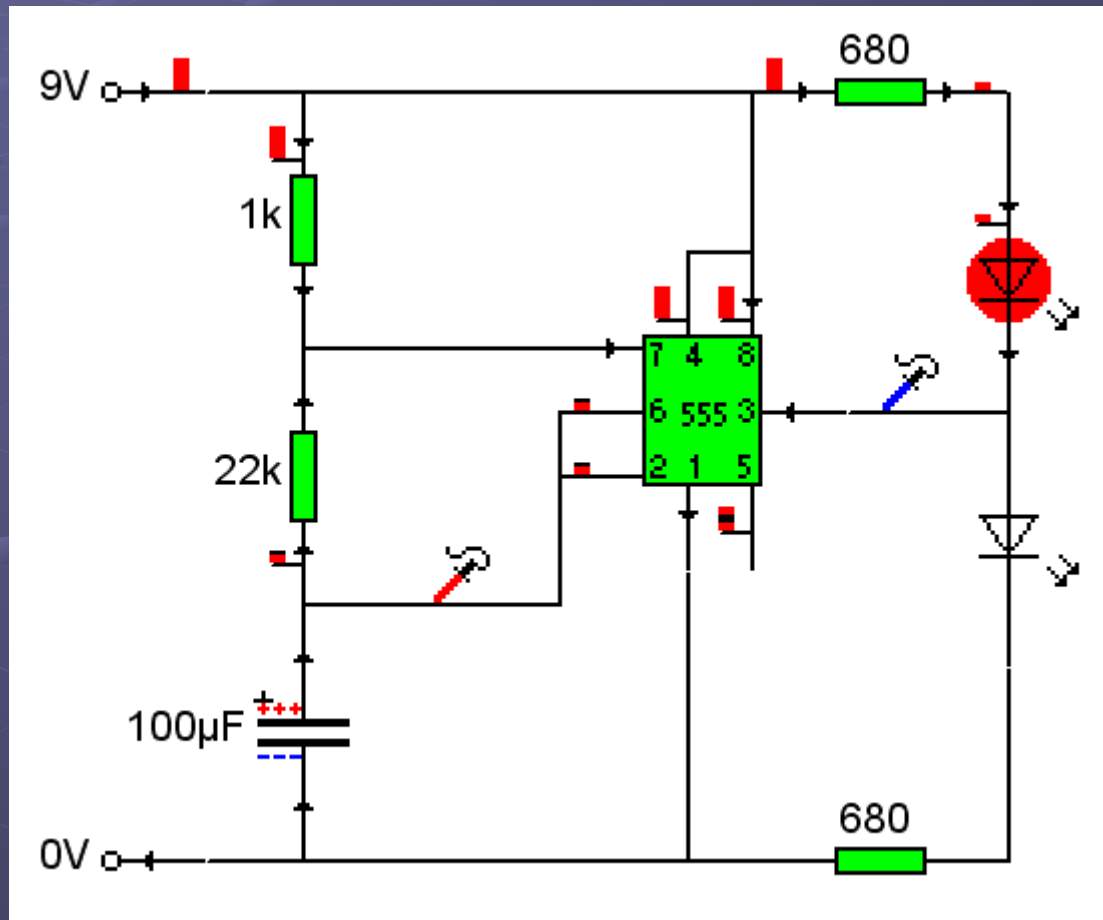

LEDs in Rolling Stock

- The biggest problem is getting reliable pickup from wheels & axles, and avoiding flicker
- DCCconcepts (Gaugemaster)
 - Axle pickup springs
 - A flicker free unit
 - NanoLEDs

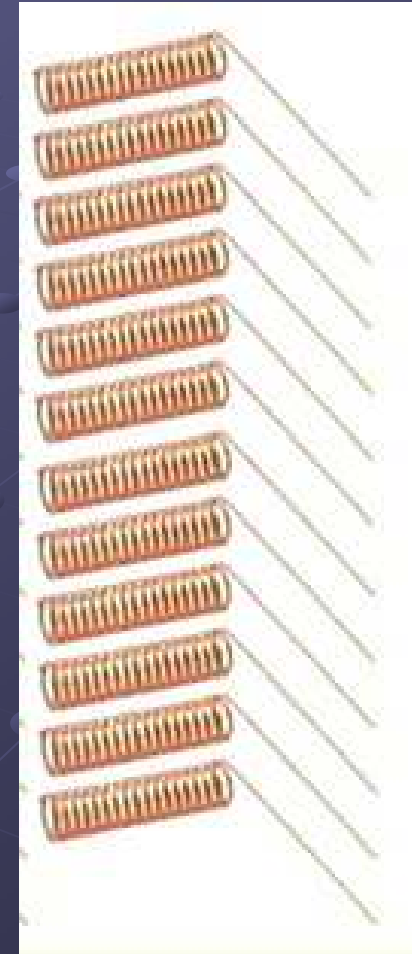
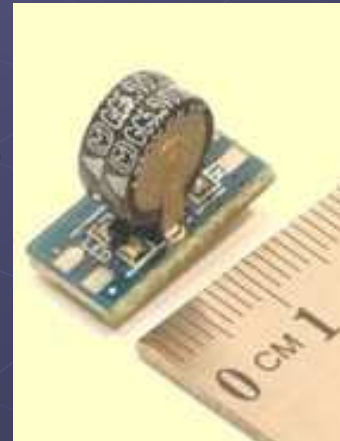

Images copyright DCCconcepts, shown with permission.



Some ideas on Wiring a Baseboard

If you have to extend wires ...

- Solder them & add heatshrink, or join them in terminal blocks/chocolate blocks. Don't solder 2 wires together just where they disappear through the baseboard.
- Keep the two wires the same colour.
- Ensure it is documented.

or

- Replace the short wire with a longer wire.

If you have to extend wires ...

- At least keep the colours across the joint

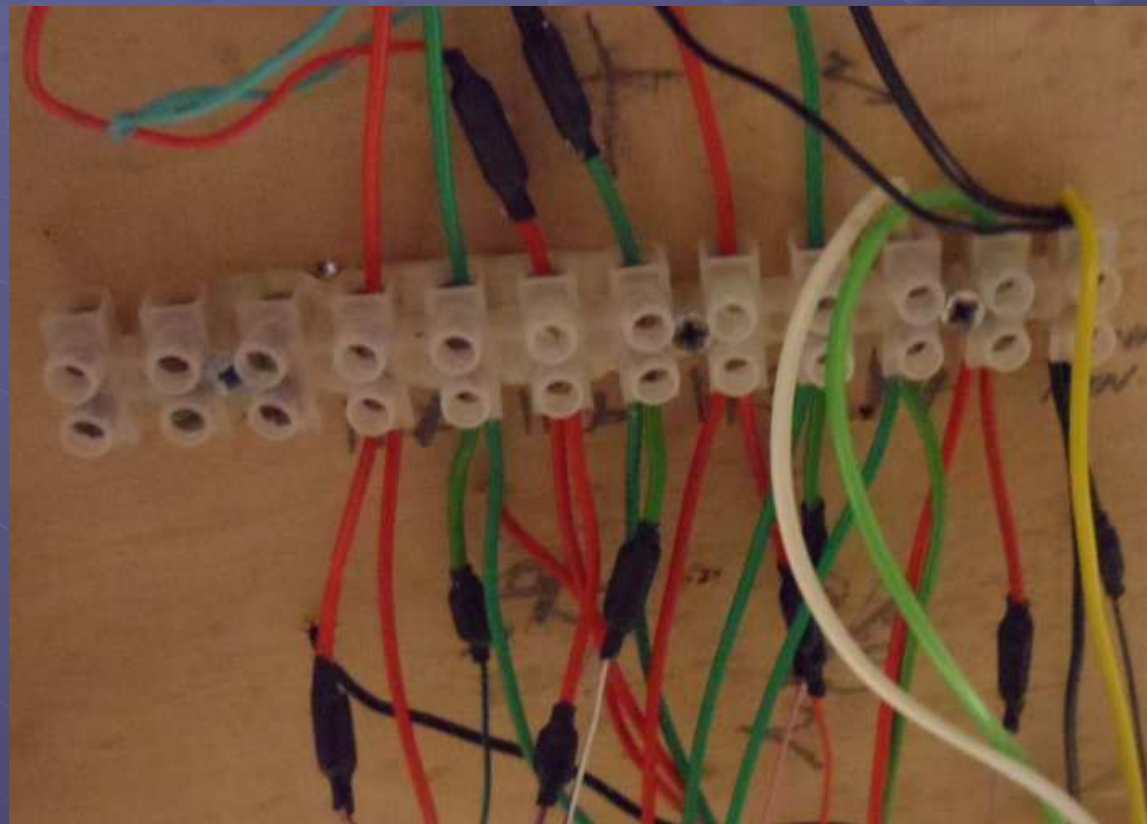

A Case Study

Corner baseboard with double Track main line & a single siding to a Gas Works.

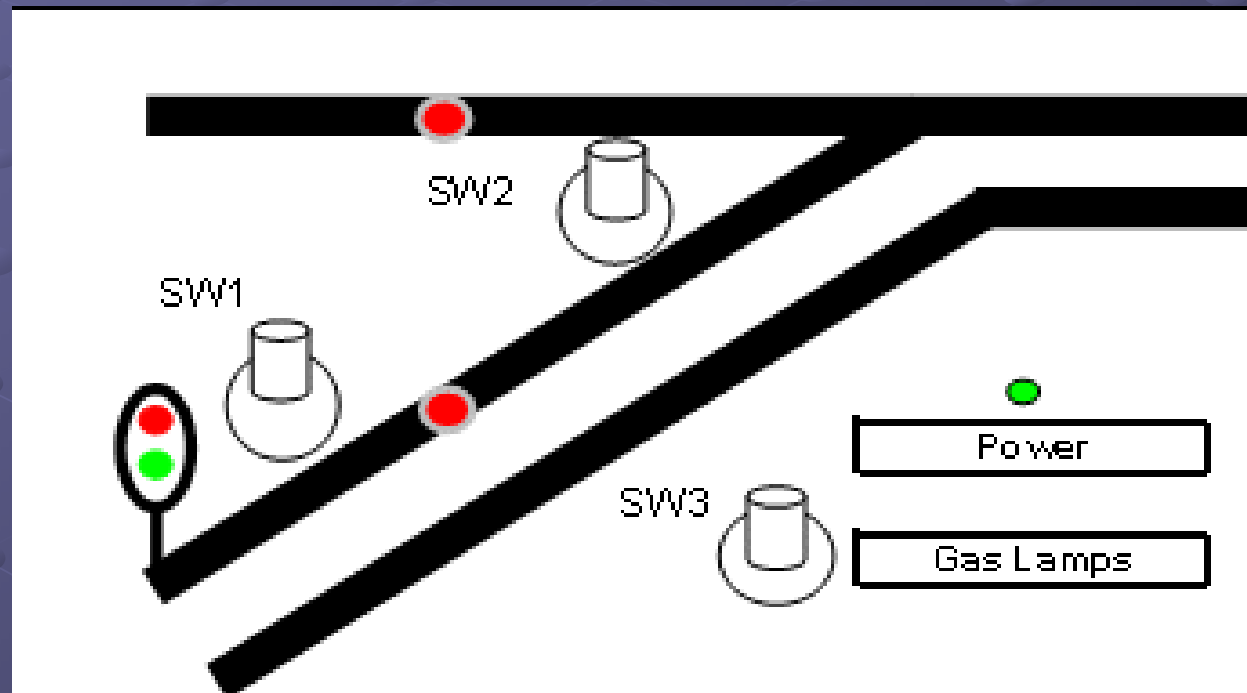

A Case Study

Even for this simple case I recommend-

- Painting the underside white.
- Document as you go along.
- Identify the wires
- Use tag strips, so wiring goes from switch to tag, then tag to point motor etc.



A Case Study

- Point interlocked with signal
- Gate to siding to open
- Automatic stop at signal when at danger

So

- when signal=red, gate opens, & point can be operated.
- When signal=green, gate closes, point set to main line & cannot be changed.

Case Study

MERG Kits used-

- Kit 61 Gas Lamp Twinkler
- Kit 74 Mark 2 relay board for interlocking etc.
- Kit 75 Servo4 for point & siding gate

Table of Wire Numbers

colours as for resistors, Wxx1 is Brown etc.

	various	various	0V supply
	various	various	+12V supply
W1	R4_Bc	Tag1_1	Point Frog
W2	R4_Bo	Tag1_3	Point Frog
W3	R4_Ao	Servo_1	Point Servo
W4	R4_Ar	R3_Ao	Point Interlock
W5	R3_Bo	Servo_3	gate servo
W6	R4_IP	R5_IP	Assymmetric DCC
W7	M olex F1	R4_IP	Point Interlock
W8	R4_Br	Tag1_2	Point Frog
W9	R5_8	V_J3_5	Assym DCC output
W10	M olex F3	R3_IP	

Auto-Documentation via Excel

Switches

Sw1 (DPDT) signals		
Pin	Wire	Connecting
1	10	R3_IP
2		
3		
4		
5		
6		

Sw2 (SPDT) Point		
Pin	Wire	Connecting
1	20	R4_IP
2		
3		

Sw3 (SPST) Gas Lamp		
Pin	Wire	Connecting
1		
2		

Tag Strips

Tag1 for Point Frog		
Pin	Wire	Connecting
1	40	R4_Bc
2	8	R4_Br
3	42	R4_Bo

PCB Outline used to identify inputs

Servos

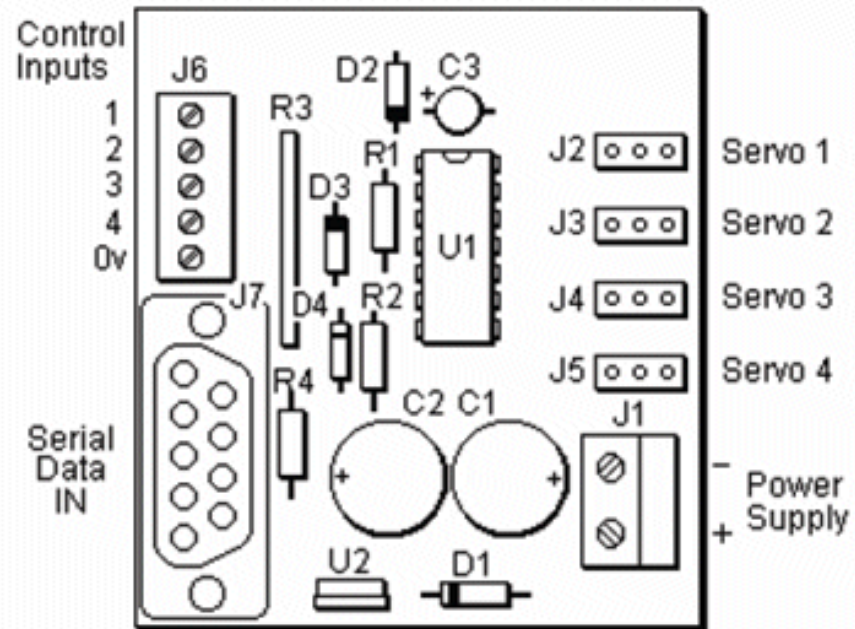

Function	Point P1		Gate		Semaphore Signal			
Input #	1	J2	2	J3	3	J4	4	J5
	Wire	Connecting	Wire	Connecting	Wire	Connecting	Wire	Connecting
IP			3	R4_Ao	5	R3_Bo	6	R2_AD

Use of Links & orientation of board

Relays

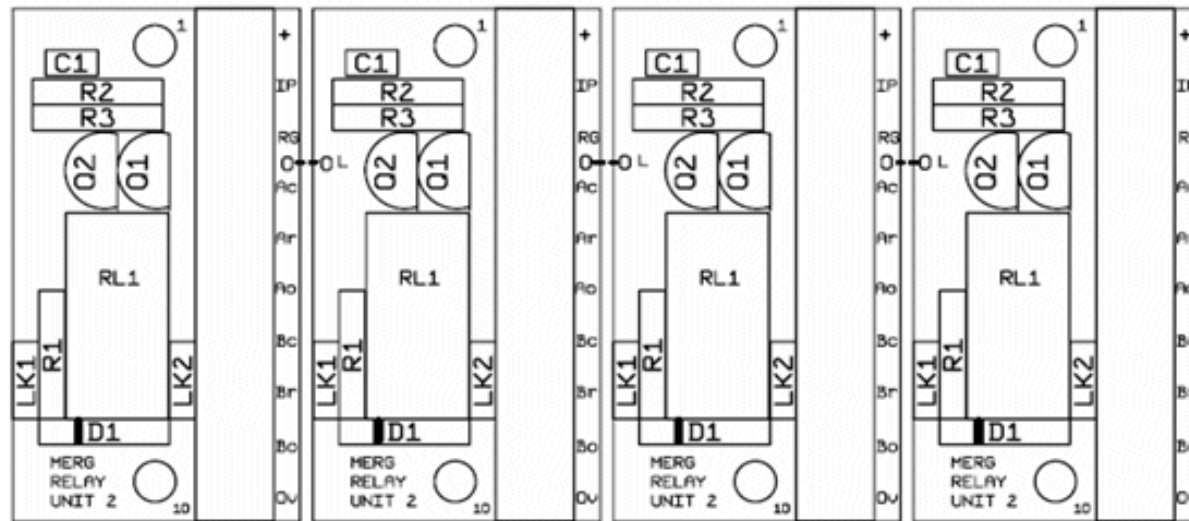

Relay #	R1	R2	R3	R4
A	Assymetric DCC	Semaphore Servo	Point Interlock Gate Servo	Point Servo Point Frog Polarity
B				
L				
L				
LK1	x	YES	YES	x
LK2	x	YES	YES	x

Relays continued

Details can be added (e.g. links).

- L Installed if adjacent relays are triggered from one input
so 1, 2 & 3 all triggered from inputs on Relay3
- LK1 installed if 0V required on relay A contact rockers (solid colour black below)
- LK2 installed if 0V required on relay B contact rockers (solid colour black below)

	R1		R2		R3		R4	
	Wire	Connecting	Wire	Connecting	Wire	Connecting	Wire	Connecting
IP	(10)		(10)		10	Sw1_1	20	Sw2_1
RG								
Ac								
Ar	50	V_J3_3					4	R3_Ao
Ao	30	V_J3_1	6	Servo_4	4	R4_Ar	3	Servo_2
Bc							40	Tag1_1
Br							8	Tag1_2
Bo					5	Servo_3	42	Tag1_3

Hardware for baseboards

(Not electronics, but useful to know)

- Station Road baseboards

<http://www.stationroadbaseboards.co.uk/>

- The Topaz Munchkin (yes really)

<http://stores.ebay.co.uk/The-Topaz-Munchkin-Store>

Electronics for Beginners: Annexes

Annex A: Further Reading

Annex B: Web Resources

Annex C: Surface Mount Soldering

A: Further Reading

Davy Dicks ebook

- Download from

<http://www.merg.org.uk/>

New Book available

MERG is pleased to announce and support the release of a new book, written by MERG member Davy Dick, entitled "Electronics for Model Railways".

This excellent publication is available for free download. [Click here to read more about it and download a copy.](#)

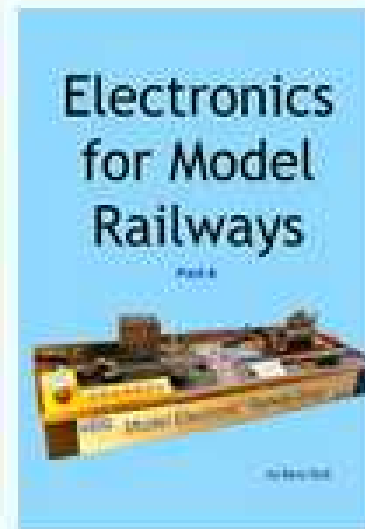

A: Further Reading

Useful TBs (Technical Bulletins)

- G16/71 & G16/72 “Layout Wiring: a radically new approach”
- LC01/02 “Guidance for Cabling Model Railways”
- P01/1 “Practical Guide to Crimping & IDC”
- P02/01 “Guidance for Building a Typical MERG Electronic Kit.”
- T33/13 “SuperBloc Power Supplies”

A: Further Reading

MERG Articles

- “Wiring for DCC” by Dick Ganderton, MERG Journal Summer 2007 p30.
- “CBUS Starter Project” by Davy Dick, MERG Journal Summer 2009 p 40, Autumn 2009 p 18, Winter 2009 p 37.
- “MERG, CBUS & DCC” by Ian Both. Download from MERG website (under “Presentations/Papers”).

A: Further Reading

Babani Books

- Beginners Guide to CMOS Digital ICs
- IC555 Projects
- Getting the Most From Your Multimeter

Not expensive (~£5)

<http://www.babanibooks.com/>

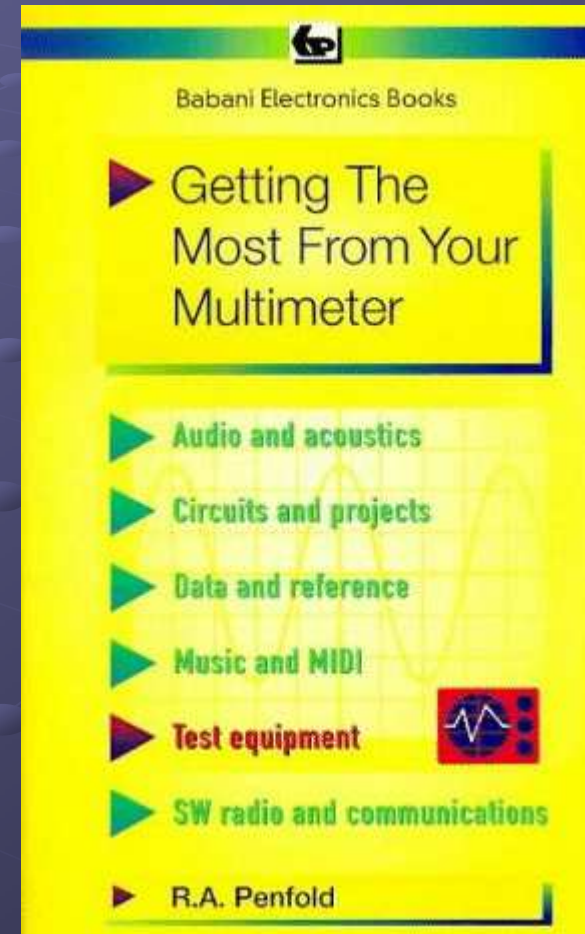

B: Web Resources

- MERG kits, videos, supplies and resources.

<http://www.merg.org.uk>

- Site maintained by ex MERG member Howard Amos. Includes TCC program (which interfaces to RPC etc.), QTU hardware etc.

<http://www.qtutrains.com>

- “A Step by Step Guide to the Complete Model Railway”. Includes advice on Soldering, Wiring etc.

<http://www.brian-lambert.co.uk>

B: Web Resources

- The Electronics Club

<http://electronicsclub.info/>

- Educational – books, PCBs etc.

<http://www.doctrronics.co.uk/>

- A Guide to soldering etched kits etc.

http://www.finescale.org.uk/index.php?route=information/information&information_id=18

- LED Tech Tips, (search for “LED Tech Tips”)

<http://www.dccconcepts.com/>

B: Web Resources - Controllers

- A review of controllers from New Zealand

<http://www.scottpages.net/ReviewOfControllers.html>

- The PICtroller, a PIC based design to replace the Pentroller as used at Pendon Museum.

<http://www.malcolmsminiatures.co.uk/>

Search for “Model railway controls”

B: Web Resources - Suppliers

- Suppliers of Electronic components & tools

<http://www.rapidonline.com/>

<http://cpc.farnell.com/>

<http://uk.mouser.com/>

B: Web Resources - DCC

- Alan Gartner's "Wiring for DCC" pages, e.g. for points/turnouts/switches

<http://www.wiringfordcc.com/switches.htm>

- Comparison of DCC *systems* (command station & throttles)

http://www.dccconcepts.com/index_files/DCCbran_decisions.htm

B: Web Resources – Downloads

Downloads from MERG website

- members only– use Software Downloads page.
<http://www.merg.org.uk/softwarewiki/doku.php>
 - CBUS
 - Crocodile Clips program for circuit simulation
 - ATC (Automatic Train Control)
 - ServoSetPlus Program
 - + loads more.
- Available for anyone
 - CreateResistor program
<http://www.merg.org.uk/resistor/index.htm#programme>

B: Web Resources - Downloads

Other sites

- An interactive program for calculating the values of resistors and capacitors for using with a 555 timer in different modes.

<http://clarkson-uk.com/555-timer/>

C: Dave Jones' Blogs on Soldering

- EEVblog #180 – Soldering Tutorial Part 1 – Tools

<http://www.eevblog.com/2011/06/19/eevblog-180-soldering-tutorial-part-1-tools/>

EEVblog #183 – Soldering Tutorial Part 2

<http://www.eevblog.com/2011/07/02/eevblog-183-soldering-tutorial-part-2/>

EEVblog #186 – Soldering Tutorial Part 3 – Surface Mount

<http://www.eevblog.com/2011/07/18/eevblog-186-soldering-tutorial-part-3-surface-mount/>

C: Surface Mount (SM)

- SM instead of “Through Hole”
- Simple SM kits - gas lamp twinkler Kit 461. Contains advice on SM.
- Apply solder to one pad (only one pad!), pick up component with tweezers, re-melt solder with iron and push the component into the pool of molten solder, remove iron and when solid remove tweezers.

Not as hard as you might think.



C: Surface Mount (SM) Drag Soldering

- There is a Forum topic on surface mount

<http://www.merg.org.uk/forum/viewforum.php?f=111>

- It includes “drag soldering” Used to fix small ICs with a large number of closely spaced pins.

<http://www.merg.org.uk/forum/viewtopic.php?f=111&t=2993>

The End

