

# **CANACC5 (Rev b)    CBUS module for motorised point drivers etc.**

## **Introduction**

CANACC5 is one of a number of layout control modules for use with the CBUS system. This is a general purpose layout control bus (LCB) using the industry standard CAN bus. For more information on CBUS, see the introductory article on this website.

CANACC5 is a 'consumer' only module which accepts and learns events sent over the CBUS by other (producer) modules. It drives 8 separate outputs using two high current 'push pull' driver ICs (SN754411 or equivalent). This module provides a wide range of supply voltages and the driver ICs have built-in diodes which allow use with inductive loads such as relays and motors without the need for external diodes.

CANACC5 follows the SLiM (Small Layout interface Model) of CBUS which allows it to be set up and taught without any need for a programming device or computer. However, like all other SLiM modules, it responds with its CAN-ID when interrogated by 'nodes' which implement the self-enumeration scheme so is compatible with the Full Model modules (FLiM).

Please refer to the schematic CANACC5\_sch.pdf.

## **Power supply.**

This module requires its own AC supply of 12 to 16V (RMS) AC at 50 / 60 Hz. This AC is rectified by a bridge rectifier (BR1) and smoothed to DC by capacitor C1. Note that some other CBUS modules also require a similar AC supply and the same transformer can be used for all.

The DC output available for driving turnout motors, relays, lights etc can be adjusted using the potentiometer VR1 over the range 5 to 15 volts. This is a useful facility as it allows for relays or lamps of 12 /14V as well as covering the 5V needed by some logic devices and also for controlling the speed of point motors. It is not possible to have different voltages for each output though unless external resistors or regulators are used. The output terminal block has the +ve supply and its 0v available on separate terminals.

There is a separate voltage regulator (U2) which supplies the rest of the circuit with a fixed 5V. This +5V is also available on the CBUS connector for powering modules that do not have their own AC inputs. The maximum current available from this regulator is 1 amp and even with no external load, a small heatsink is necessary.

The green LED (LD2) will illuminate to show the circuit is working correctly. This is not just a power on indicator but confirms correct working of the processor.

## **Output drive capability.**

Each of the outputs can source or sink a current of 1 amp maximum but the total instantaneous current is limited to 1.5 amps by the adjustable regulator (U4) and the average current is further limited by the rectifier BR1 which is rated at 1 amp continuous. Hence short duration pulses of 1 amp per output can be used for solenoids or motors but the maximum continuous current with all outputs active must be less than 1 amp. Depending on the voltage setting with VR1, the regulator U4 will need substantial heatsinking if heavy current loads are expected. When driving conventional LEDs, an external series resistor is required for each LED. CANACC5 is designed for continuous on or off outputs and does not have a capability to generate short pulses of itself. However, short bursts can be effected by sending an ON event followed by an OFF event to the same output.

## Connecting the module

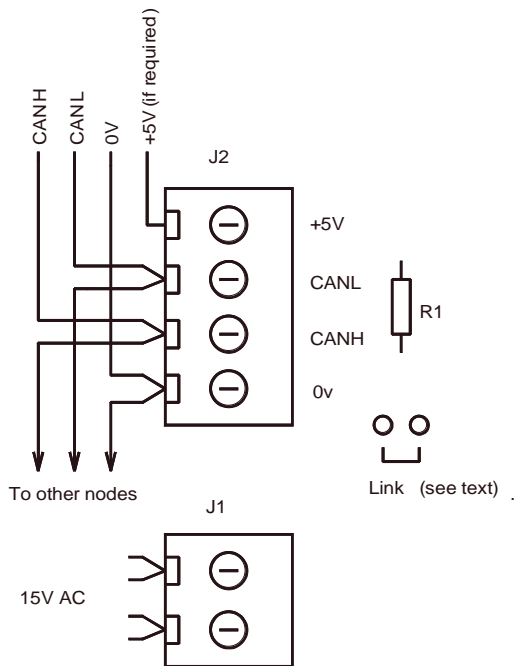

The CANH and CANL wires go to all modules. They are polarity sensitive so CANH must go to CANH and CANL to CANL. These wires should ideally be a twisted pair although screening is not necessary. While it would be usual to wire the bus sequentially round the various modules, it is not essential and individual nodes can be 'star' connected if this is more convenient. The CBUS wiring should be kept separated from any DCC supply wiring to prevent possible interference.

The CAN bus requires 'termination' resistors at some point in the network. If the bus is wired sequentially round the modules, then a resistor of 120 ohms should be fitted across the bus at each end. For small layouts, it is sufficient to have a resistor across the bus at one point. The value is not critical and a 68 ohm resistor will suffice.

The CANACC5 module has the ability to supply 5V to other modules that do not have the 15V AC supply input. If this is a requirement, then the link as shown in the diagram must be fitted. Where a number of modules are powered off the same 15V AC supply, it is preferable to also connect the 0V line but the link must not be fitted or high currents may flow between these modules in the 0V line. (where a set of modules are all powered off the same 15V transformer, it is possible to omit the 0V line altogether.) Also where the modules are AC powered, the 5V line on the CBUS connector must not be connected to other powered modules. If you have a mixture of powered and non-powered modules, the 5V supply should be 'shared out' so no single module supplies all the unpowered ones.

## Training the module.

The training process is a unique aspect of CBUS and provides a very powerful method of configuration without the need for any programming device or knowledge of how the system works. The CANACC5 module has a 6 way DIL switch for training.

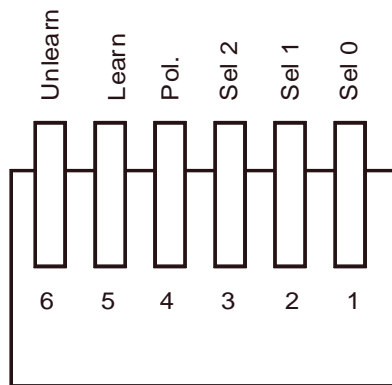

DIL switch Top view

The three 'Sel' switches select which output the 'event' will apply to. There are 8 outputs numbered 1 to 8. The three switches allow a selection of one of the 8 outputs using a binary sequence. When the switch is 'down' (ON as written on the switch) this represents a logic 0. A switch in the up (OFF) position is a logic 1. With all three switches down, this gives a value of binary 000 and selects output 1

The following table gives all the possible combinations.

Sel 2	Sel 1	Sel 0	Output
on	on	on	1
on	on	off	2
on	off	on	3
on	off	off	4
off	on	on	5
off	on	off	6
off	off	on	7
off	off	off	8

To train the CANACC5 module, you need a CBUS 'producer' module which creates events. This could be a CANACE3 control panel scanner, a CANACE8 or 8C switch input module or a PC program which creates events via a CAN-RS module.

Connect the various modules and apply power. Connect the 'devices' you want the CANACC5 to operate to the output terminals. Remember to adjust the output voltage with VR1 to the desired value. This

supply is available on J3 pins 1 (0V) and pin 10 (5 to 15v). Select the output you want the event to operate with the Sel switches according to the above table. Put the 'learn' switch to ON (down). Send the event. If it is an ON event, then the corresponding output will turn on. Try it with the same event number but as an OFF event. The output should now go off. Move the learn switch to OFF (up). Test the event again. The output should go on or off as expected.

Now comes the interesting bit. A single event can activate more than one output. Set the Sel switches to another output and put into learn mode. Send the same event as previously. Now both outputs will be activated. Repeat if wanted for more outputs. This process allows a single event (like a switch change on a control panel) to create a combination of outputs (256 possibilities) for setting routes, signal aspects or alpha-numeric displays.

CANACC5 is a multi-purpose module with essentially 8 separate outputs. However, the bi-directional drive capability of the output stages allows outputs to work in complementary pairs as required for motorised turnout drivers such as 'Tortoises' or 'Fulgurex' devices. This requires the output pairs to be set to 'toggle' as follows.

The next option is the use of the 'Pol' switch. With the Pol switch off, an ON event will turn an output on and vice versa. However, it is possible to reverse this by putting the Pol switch ON when learning the event. Consequently a single event can set some outputs ON and some OFF at the same time. For example, if output 1 is set normally and output 2 is set with the polarity reversed but with the same event, sending that event will cause outputs 1 and 2 to 'toggle' so an ON event will put output 1 on and output 2 off. An OFF event will reverse the outputs. This can be applied to any or all of the outputs.

If you want the module to forget an event it has learned, (remove it altogether), set both the learn and unlearn switches ON and send that event.

Note that different events can set the same combination of outputs. This can be useful if you want switches on different control panels or a combination of control panel and PC events to have the same effect.

## Limitations.

The present firmware sets the number of stored events to 32. If you try to set more than 32, no more will be added but the yellow LED (LD1) will flash to indicate the event stack is full.

You can add more outputs to an event and alter the polarity for an existing output but you cannot remove an output from an event once set. If you want to remove an output, you need to erase the whole event and teach it again.

If you have forgotten which events the module has been taught, then you cannot tell it to unlearn an event that you don't know it has! In this case there is a 'clear all' option. This removes completely all stored events. To do this, set the unlearn switch to ON with the learn switch OFF. Remove power from the module and then reapply it. This will clear the memory. Remember to switch off the unlearn switch after this process.

J3

1	○	0v
2	○	Output 1
3	○	Output 2
4	○	Output 3
5	○	Output 4
6	○	Output 5
7	○	Output 6
8	○	Output 7
9	○	Output 8
10	○	+ve supply (5 to 15 V)

The output connector

The SLiM PCBs include provision both for in-circuit serial programming and debugging (ICSP) and two LEDs driven off the programming pins. These LEDs and associated resistors are for diagnostic purposes and may be omitted. Where fitted, low current LEDs are recommended. For 2mA LEDs, a value of 1K8 or 2K2 is suitable for resistors R8 and R9.

The small pushbutton S1 is intended for use if the module is upgraded to the Full (FLiM) model. It is not used in SLiM mode or with the SLiM firmware and can be omitted.

A diagnostics and test program is being developed for CBUS. This will entail additions to the microcontroller firmware on the module which will be posted when available.

Resistor R7 determines the rise and fall times of the CAN waveform. Until such time as an optimal value has been determined, R7 should be just a wire link (zero ohms) which sets the maximum available rates.

The full schematic, a PCB layout which is in .PDF form and can be printed to the exact size for making masks and the PIC assembly and HEX code are available on the MERG website. These can be freely used for non-commercial purposes. Copyright to the designs is held by the authors.

Mike Bolton & Gil Fuchs

4<sup>th</sup> May 2008

CANACC5 Rev b

©