

# **CANACE3            CBUS module for Control Panels**

## **Introduction**

CANACE3 is one of a number of layout control modules for use with the CBUS system. This is a general purpose layout control bus (LCB) using the industry standard CAN bus. For more information on CBUS, see the introductory article on this website.

CANACE3 is a 'producer' only module which sends events over the CBUS to consumer modules. It is intended for use on conventional control panels with 'mimic' diagrams to operate turnouts or set complete routes.

CANACE3 follows the SLiM (Small Layout interface Model) of CBUS which allows it to be given a Node Number (NN) by onboard jumpers. No programming is necessary. For practical reasons, the present CANACE3 module only allows 4 node numbers to be set. This limits the number of control panels using this module to 4. However, like all other SLiM modules, it responds with its CAN-ID when interrogated by 'nodes' which implement the self-enumeration scheme so is compatible with the Full Model modules (FLiM).

CANACE3 can scan up to 128 on / off switches creating 128 ON / OFF events or, by changing an on-board jumper, can scan 64 pairs of push-buttons (PBs) or 'centre off' toggle switches, giving 64 separate ON or OFF events.

Please refer to the schematic CANACE3\_sch.pdf.

## **Power supply.**

This module requires its own AC supply of 12 to 15V (RMS) AC at 50 / 60 Hz. This AC is rectified by a bridge rectifier (BR1) and smoothed to DC by capacitor C1. Note that some other CBUS modules also require a similar AC supply and the same transformer can be used for all.

There is a separate voltage regulator (U2) which supplies the rest of the circuit with a fixed 5V. This +5V is also available on the CBUS connector for powering modules that do not have their own AC inputs. The maximum current available from this regulator is 1 amp and even with no external load, a small heatsink is necessary.

The green LED (LD2) will illuminate to show the circuit is working correctly. This is not just a power on indicator but confirms correct working of the processor.

## **The switch matrix scanning method.**

The control panel switches are interrogated using a conventional diode matrix method. This allows a large number of switches to be connected with relatively little wiring. Only 24 wires for 128 switches or 64 PB pairs. The matrix is arranged as 16 columns and 8 rows. Each column is pulsed from 5V (high) to 0V (low) in turn on a cyclical basis. The rows are connected to the columns via a switch and a series diode. If a switch is closed, the corresponding row is taken low when the column goes low. The voltage drop across the series diode still gives a logic low with the CMOS inputs of the PIC processor. Unlike similar arrangements for keypad scanning where only one button is pressed at one time, the diodes are required as switches may remain closed.

The processor firmware detects changes in the switches or PBs and sends a corresponding CBUS event. When in switch mode, a switch closure sends an ON event and a switch

opening sends an OFF event. In accord with the CBUS protocol, the event is a 32 bit (4 byte) number. The upper two bytes are the Node Number, in the case of CANACE3 this range is 1 to 4 only. The lower two bytes are the node event. Again, for CANACE3, these numbers start at 1 and run sequentially to 128 (or 1 to 64 for the dual pushbutton mode). Event or NN of zero is not used.

To further simplify the control panel wiring, the numbering sequence starts at 1 with column 1 and row 1, 2 with column 1 and row 2, 3 with column 1 and row 3 and 4 with column 1 and row 4. However, event 5 is column 2 and row 1 (not column 1 and row 5) so only the first 4 rows are used for events 1 to 64 and the second set of rows (5 to 8) for events 65 to 128. This allows for a sequential set of events for smaller control panels using only 4 row wires total. The same applies in PB mode but each column generates 2 events for the 4 rows so rows 1 to 4 give events 1 to 32 and rows 5 to 8 give events 33 to 64. All matrix wiring is conveniently supplied via a 25 way D type socket. The pinout is given on the schematic.

Selection of switch mode or push button mode is via the jumper J5. J5 has three pins. Placing the jumper between the centre and lower pins sets 'switch' mode and between the centre and upper pins, selects the PB mode. (Viewed with the regulator U2 at the top)

### Connecting the module

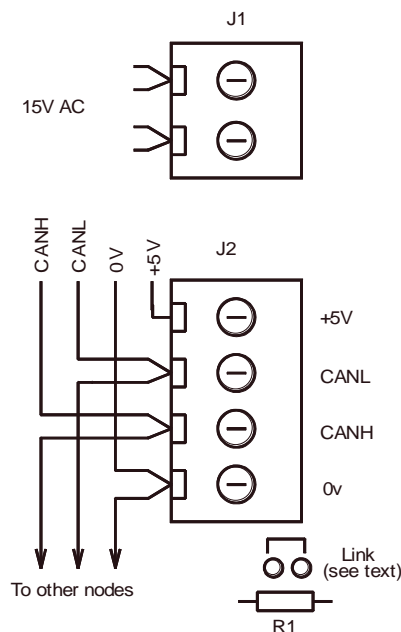

The CANH and CANL wires go to all modules. They are polarity sensitive so CANH must go to CANH and CANL to CANL. These wires should ideally be a twisted pair although screening is not necessary. While it would be usual to wire the bus sequentially round the various modules, it is not essential and individual nodes can be 'star' connected if this is more convenient. The CBUS wiring should be kept separated from any DCC supply wiring to prevent possible interference.

The CAN bus requires 'termination' resistors at some point in the network. If the bus is wired sequentially round the modules, then a resistor of 120 ohms should be fitted across the bus at each end. For small layouts, it is sufficient to have a resistor across the bus at one point. The value is not critical and a 68 ohm resistor will suffice.

The CANACE3 module has the ability to supply 5V to other modules that do not have the 15V AC supply input. If this is a requirement, then the link as shown in the diagram must be fitted. Where a number of modules are powered off the same 15V AC supply, it is preferable to also connect the 0V line but the link must not be fitted or high currents may flow between these modules in the 0V line. Also where the modules are AC powered, the 5V line on the CBUS connector must not be connected to other powered modules. If you have a mixture of powered and non-powered modules, the 5V supply should be 'shared out' so no single module supplies all the unpowered ones.

## Setting the node number.

Purely due to hardware restraints (not enough pins on the PIC), the CANACE3 module only allows four node numbers. These are selected as a binary sequence with jumpers Sel 0 and Sel 1. The actual binary numbers are 0, 1, 2 and 3 although the firmware adds one so the NNs run from 1 to 4. A logical 0 is with the jumper in.

The following table gives all the possible combinations. The node number may be changed while the module is running.

Sel 1	Sel 0	Node Number
in	in	1
in	out	2
out	in	3
out	out	4

As with all CBUS SLiM producer modules, no two modules should have the same Node Number. Thus, if a layout uses all four CANACE3 modules, other producer modules should start at Node Number 5. If only one CANACE 3 module is used, it is recommended to set it at Node Number 1 and then others can start at 2. In the unusual case where you may want two identical control panels, having the same switch arrangement and controlling exactly the same devices, it is possible to give them both the same Node Number. They will then produce identical events for each switch.

## Limitations.

The presently available CAN transceivers set a maximum number of CAN nodes on any one 'segment' to 110. Although the current SLiM scheme only allows 16 producer modules, there is no limit to the number of consumer modules so care must be taken not to overload the CAN bus. The Full Model (FLiM) scheme allows for 65536 modules which will be programmable over the CBUS itself. Here, we intend to develop modules to bridge between many CAN segments (CAN-CANs).

The SLiM PCBs include provision both for in-circuit serial programming and debugging (ICSP) and two LEDs driven off the programming pins. These LEDs and associated resistors are for diagnostic purposes and may be omitted. Where fitted, low current LEDs are recommended. For 2mA LEDs, a value of 1K8 or 2K2 is suitable for resistors R6 and R7.

The small pushbutton S1 is intended for use if the module is upgraded to the Full (FLiM) model. It is not used in SLiM mode or with the SLiM firmware and can be omitted.

A diagnostics and test program is being developed for CBUS. This will entail additions to the microcontroller firmware on the module which will be posted when available.

Resistor R5 determines the rise and fall times of the CAN waveform. Until such time as an optimal value has been determined, R5 should be just a wire link (zero ohms) which sets the maximum available rates.

The full schematic, a PCB layout which is in .PDF form and can be printed to the exact size for making masks and the PIC assembly and HEX code are available on the MERG website.

These can be freely used for non-commercial purposes. Copyright to the designs is held by the authors.

Mike Bolton & Gil Fuchs

4<sup>th</sup> May 2008

