

Glossary C

[Return to main Glossary index](#)

C/MRI

Bruce Chubb's Computer/Model Railroad Interface system C/MRI. A series of modules and support available for the system obtained from JLC Enterprises Inc. For website see [links page](#)

Cab Control

A system of control using DC power where more than one controller or cab is used to drive trains across the tracks controlled by another controller. This requires switches to transfer the supply from the cabs to the parts of the layout they will control, the switches preventing two or more cabs controlling simultaneously the same section of track.

Cabling

Refer to [MERG TB](#) on layout cabling LC01 (Note available to members only)

CAN

Refers to Controller Area Network, and is a bus standard designed to allow microcontrollers and devices to communicate with each other. It is a message-based protocol, designed specifically for automotive applications but now also used in other areas including MRR. Development of CAN bus was invented in 1983 by Robert Bosch. See: [CAN_bus](#)

Capacitor

A capacitor can store electric energy when disconnected from its charging circuit, so it can be used like a temporary battery.

[Main article](#)

Carlos

A computer programme for creation of model railway control panels on screen. Carlos is a DOS program developed by MERG member John Down and can be used with the RPC system. See TB G18/1 or follow this link for more information.

CBus

Layout control bus, see [CBus resources page](#)

CDU

Its short for capacitor discharge unit (CDU). Its use is generally to store a high voltage charge which is released very quickly to kick start solenoid operated point motors.

CE

The CE mark (officially CE marking) is a mandatory marking on certain products, which is required if they are placed on the market in the European Economic Area (EEA). By affixing the CE marking, the manufacturer, or its representative, or the importer assures that the item meets all the essential requirements of all applicable EU directives. Examples of European Directives requiring CE marking: Toys-, Machinery-, Low Voltage equipment-, R&TTE-, EMC-Directive. There are about 25 Directives requiring CE marking.

Ceramic

The word ceramic is derived from the Greek word κεραμικός (keramikos, "having to do with pottery"). The term covers inorganic non-metallic materials whose formation is due to the action of heat. This can refer to the packaging of integrated circuits in a ceramic material.

Channel

Programmable 4 - channel Servo Driver Type 'Servo4' For operation of model railway accessories such as turnouts and semaphore signals. The word channel refers to the ability to control 4 devices. See the MERG newsletter (now called a Journal) of [March 2006](#) pages 8 and 9 on the web site.

Charlieplexing

Charlieplexing is a method of matrix multiplexing which uses each wire in turn as the sink. See the MERG newsletter (now called a Journal) of [March 2006](#) pages 34 and 35 on the web site.

Circuit

An electrical circuit is a network that has a closed loop, giving a return path for the current and

usually connecting a series of electrical components.

Cleaning Tracks

There is a commercial product called Relco. More information on cleaning tracks can be obtained from Southern E-Group web site.

<http://freespace.virgin.net/c.gardner/semg/relco.htm>

Clearing point

This is a location in advance of a signal box up to which the track must be clear to allow a signalman to accept a train into a block section.

See the MERG newsletter (now called a Journal) of [March 2006](#) pages 23 on the web site.

Clock

In electronics and especially synchronous digital circuits, a clock signal is a signal used to coordinate the actions of two or more circuits. A clock signal oscillates between a high and a low state, normally with a 50% duty cycle, and is usually a square wave. Circuits using the clock signal for synchronization may become active at either the rising or falling edge, or both.

A crystal oscillator is often used in electronic circuits (sometimes abbreviated to XTAL on schematic diagrams) This uses the mechanical resonance of a vibrating crystal of piezoelectric material to create an electrical signal with a very precise frequency. This frequency is commonly used to keep track of time (as in quartz wristwatches), to provide a stable clock signal for digital integrated circuits, and to stabilize frequencies for radio transmitters.

Using an amplifier and feedback, it is an especially accurate form of an electronic oscillator. The crystal used therein is sometimes called a "timing crystal".

Closed loop

To avoid the problems of the open-loop controller, control theory introduces feedback. A closed-loop controller uses feedback to control states or outputs of a dynamical system. Its name comes from the information path in the system: process inputs (e.g. voltage applied to a motor) have an effect on the process outputs (e.g. velocity or position of the motor), which is measured with sensors and processed by the controller; the result (the control signal) is used as input to the process, closing the loop.

CMOS

CMOS ("see-moss"), which stands for complementary metal-oxide semiconductor, is a major class of integrated circuits. CMOS chips include microprocessor, microcontroller, static RAM, and other digital logic circuits. The central characteristic of the technology is that it only uses significant power when

its transistors are switching between on and off states. Consequently, CMOS devices use little power and do not produce as much heat as other forms of logic. CMOS also allows a high density of logic functions on a chip.

The word “complementary” refers to the fact that the design uses pairs of transistors for logic functions, only one of which is switched on at any time.

The phrase “metal-oxide-semiconductor” is a reference to the nature of the fabrication process originally used to build CMOS chips. That process created field effect transistors having a metal gate electrode placed on top of an oxide insulator, which in turn is on top of a semiconductor material. Instead of metal, today the gate electrodes are almost always made from a different material, polysilicon, but the name CMOS nevertheless continues to be used for the modern descendants of the original process.

Coil

In electrical engineering, an electromagnetic coil is formed when a metallic or conductive wire is looped around a core to create an electronic inductor or electromagnet. One loop of wire is usually referred to as one turn. A coil consists of one or more turns. For use in an electronic circuit, electrical connection terminals called taps are often connected to a coil. Coils are often coated with varnish and/or wrapped with insulating tape to provide additional insulation and secure them in place. A completed coil assembly with taps etc. is often called a winding. A transformer is an electromagnetic device that has a primary winding and a secondary winding that transfers energy from one electrical circuit to another by magnetic coupling without moving parts. The term tickler coil usually refers to a third coil placed in relation to a primary coil and secondary coil.

Colour light

Refers in model railways to model signals with coloured LED or incandescent lights for red, yellow, and green.

Com port

In computer hardware, a port serves as an interface between the computer and other computers or devices in the form of an electrically wired outlet on a piece of equipment into which a plug or cable connects. These hardware ports have different physical shapes such as male, female, round, rectangular, square, oblong, etc. There is some standardization to physical properties and function. For instance, most computers have a keyboard port (currently round, or telephone type), into which the keyboard is connected.

Hardware ports can almost always be divided into two groups:

- Serial ports send and receive one bit at a time via a single wire pair (Ground and +/-).
- Parallel ports send multiple bits at the same time over several sets of wires.

A Software Port (usually just called a 'port') is a virtual data connection that can be used by programs to exchange data directly, instead of going through a file or other temporary storage location. The most common of these are TCP and UDP ports which are used to exchange data between computers on the Internet.

Command station

The Command Station is the brains of a DCC system of control and is in control of the whole system. After receipt of requests from one or several cabs or throttles, the command station's internal computer translates these cab requests into decoder commands in the form of digital packets. These are received via the track in the decoders fitted in locomotives or other accessory decoders such as the type used to control points and signals.

Common

A wire or connector that is Common or connected to all the components of a circuit.

Common Return Wiring

Is one way of wiring a model railway with fewer wires

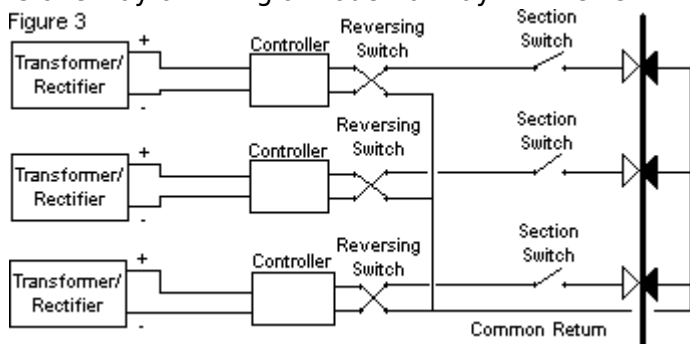

<http://rail.felgall.com/crw.htm>

Computer Control Software

Software designed specifically to control the activities of a model railway. Can provide a visual indication on the computer screen of every aspect of the control system. There are commercial software systems available as well as software developed by MERG members.

Conductor

Conductors are materials that allow electrical charges to flow through them. They are the opposite of insulators. Also see semi-conductor.

Control Systems

A Control System as applied to model railways can be any system that controls the activities of the railway.

Crystal

Oscillator that uses a quartz Crystal in its feedback path to maintain a stable output frequency.

CSA

Believed to be an out dated method of assessment overtaken by the CE marking on products.

Current

Electric current is by definition the flow of electric charge. The SI unit of electric current is the ampere (A)

Measured in amperes, it is the flow of electrons through a conductor. Also know as electron flow.

Current shunt

In electronics, a Current Shunt is a device which allows electrical current to pass around another point in the circuit.

CVs

A CV is a Configuration Variable that is a characteristic of a DCC decoder that can be customised by the user. CV's are defined by the NMRA. For example the address of a locomotive is located in CV1. Significant modifications can be made to the performance of a locomotive by changing the CV's.

From:

https://www.merg.org.uk/merg_wiki/ - **MERG Wiki**

Permanent link:

https://www.merg.org.uk/merg_wiki/doku.php?id=glossary:glossary_c&rev=1451828964

Last update: **2016/08/02 09:17**

